

**LEIF MEJLBRO**

**REAL FUNCTIONS IN ONE VARIABLE -  
ELEMENTARY...**

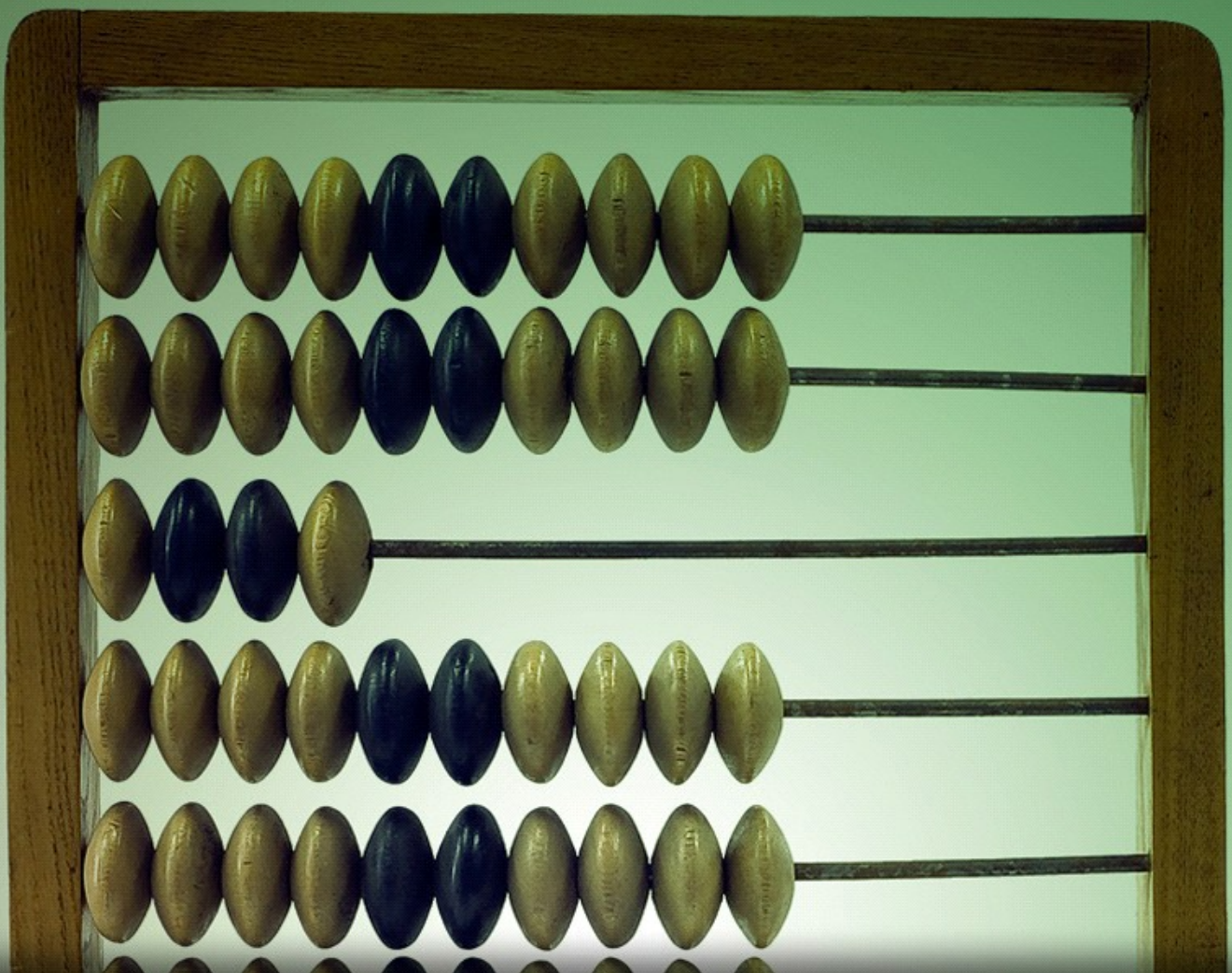

DOWNLOAD FREE TEXTBOOKS AT  
**BOOKBOON.COM**

Leif Meilbro

---

Real Functions in One Variable

Examples of Elementary Functions

Calculus 1c-2

---

---

Real Functions in One Variable – Examples of Elementary Functions – Calculus 1c-2  
© 2007 Leif Mejlbro & Ventus Publishing ApS  
ISBN 978-87-7681-237-9

# Contents

	<b>Preface</b>	<b>5</b>
<b>1.</b>	<b>Some Functions known from High School</b>	<b>6</b>
<b>2.</b>	<b>The hyperbolic functions</b>	<b>37</b>
<b>3.</b>	<b>Inverse functions, general</b>	<b>42</b>
<b>4.</b>	<b>The Arcus Functions</b>	<b>46</b>
<b>5.</b>	<b>The Area functions</b>	<b>81</b>

Please click the advert

## WHAT'S MISSING IN THIS EQUATION?

You could be one of our future talents

### MAERSK INTERNATIONAL TECHNOLOGY & SCIENCE PROGRAMME

Are you about to graduate as an **engineer** or **geoscientist**? Or have you already graduated?  
If so, there may be an exciting future for you with A.P. Moller - Maersk.



**MAERSK**

[www.maersk.com/mitas](http://www.maersk.com/mitas)

## Preface

In this volume I present some examples of *Elementary Functions*, cf. also *Calculus 1a, Functions of One Variable*. Since my aim also has been to demonstrate some solution strategy I have as far as possible structured the examples according to the following form

**A** *Awareness*, i.e. a short description of what is the problem.

**D** *Decision*, i.e. a reflection over what should be done with the problem.

**I** *Implementation*, i.e. where all the calculations are made.

**C** *Control*, i.e. a test of the result.

This is an ideal form of a general procedure of solution. It can be used in any situation and it is not linked to Mathematics alone. I learned it many years ago in the Theory of Telecommunication in a situation which did not contain Mathematics at all. The student is recommended to use it also in other disciplines.

One is used to from high school immediately to proceed to **I. Implementation**. However, examples and problems at university level are often so complicated that it in general will be a good investment also to spend some time on the first two points above in order to be absolutely certain of what to do in a particular case. Note that the first three points, **ADI**, can always be performed.

This is unfortunately not the case with **C Control**, because it from now on may be difficult, if possible, to check one's solution. It is only an extra securing whenever it is possible, but we cannot include it always in our solution form above.

I shall on purpose not use the logical signs. These should in general be avoided in Calculus as a shorthand, because they are often (too often, I would say) misused. Instead of  $\wedge$  I shall either write "and", or a comma, and instead of  $\vee$  I shall write "or". The arrows  $\Rightarrow$  and  $\Leftrightarrow$  are in particular misunderstood by the students, so they should be totally avoided. Instead, write in a plain language what you mean or want to do.

It is my hope that these examples, of which many are treated in more ways to show that the solutions procedures are not unique, may be of some inspiration for the students who have just started their studies at the universities.

Finally, even if I have tried to write as careful as possible, I doubt that all errors have been removed. I hope that the reader will forgive me the unavoidable errors.

Leif Mejlbro  
17th July 2007

# 1 Some Functions known from High School

**Example 1.1** Differentiate each of the following functions:

1)  $y = \ln(2x)$ ,

2)  $y = \cos \sqrt{x}$ ,

3)  $y = \sin^2 x$ ,

4)  $y = \sin(x^2)$ ,

5)  $y = x^2 e^x$ ,

6)  $y = \frac{\tan x}{x}$ .

**A.** Simple differentiations.

**D.** Determine where the function is defined and where it is differentiable. Then apply some well-known rules of differentiation.

**I.** 1) The function  $y = \ln(2x)$  is defined and differentiable for  $x > 0$ . Since

$$\ln(2x) = \ln 2 + \ln x,$$

we get

$$\frac{dy}{dx} = \frac{1}{x} \quad \text{for } x > 0.$$

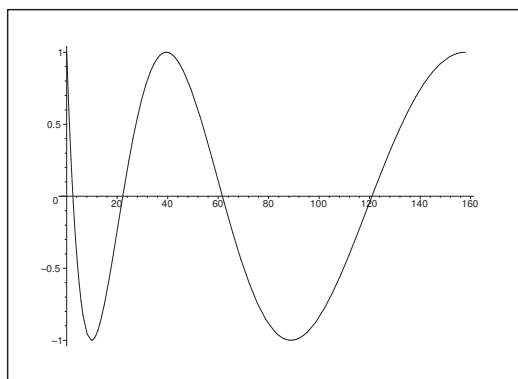

Figure 1: The graph of  $y = \cos \sqrt{x}$ ,  $x \geq 0$ ; different scales on the axes.

2) The function  $y = \cos \sqrt{x}$  is defined for  $x \geq 0$  and differentiable for  $x > 0$  with

$$\frac{dy}{dx} = -\frac{1}{2\sqrt{x}} \sin \sqrt{x}.$$



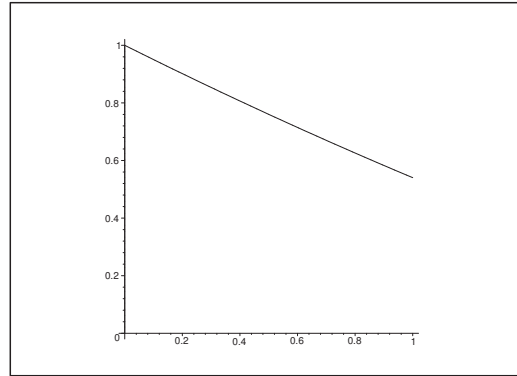

Figure 2: The graph of  $y = \cos \sqrt{x}$  in the neighbourhood of  $x = 0$ .

One should also check whether the function is differentiable from the right at  $x = 0$ , where  $y = 1$ . The difference quotient is given by

$$\frac{\varphi(x) - \varphi(0)}{x - 0} = \frac{\cos(\sqrt{x}) - 1}{x} = \frac{1 - \frac{1}{2!}(\sqrt{x})^2 + \dots - 1}{x} = -\frac{1}{2} + \varepsilon(x),$$

and we see that it converges towards  $-\frac{1}{2}$  for  $x \rightarrow 0+$ . Therefore, we conclude that the function has a half tangent at  $x = 0+$ ,  $\varphi'(0+) = -\frac{1}{2}$ .

Please click the advert

# CHALLENGE YOURSELF

## WWW.STUDYINSWEDEN.SE

Today's job market values ambitious, innovative, perceptive team players. Swedish universities foster these qualities through a forward-thinking culture where you're close to the latest ideas and global trends.

**Si.**  
Swedish Institute

Whatever your career goals may be, studying in Sweden will give you valuable skills and a competitive advantage for your future. [www.studyinsweden.se](http://www.studyinsweden.se)

- 3) The function  $y = \sin^2 x$  is defined and differentiable for every  $x \in \mathbb{R}$ , and

$$\frac{dy}{dx} = 2 \sin x \cos x = \sin(2x).$$

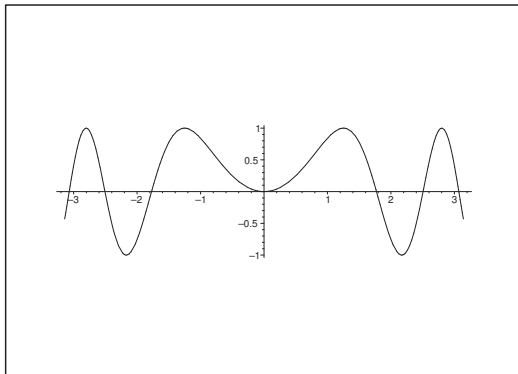

Figure 3: The graph of  $y = \sin(x^2)$ .

- 4) The function  $y = \sin(x^2)$  is defined and differentiable for every  $x \in \mathbb{R}$  and

$$\frac{dy}{dx} = \cos(x^2) \cdot 2x = 2x \cos(x^2).$$

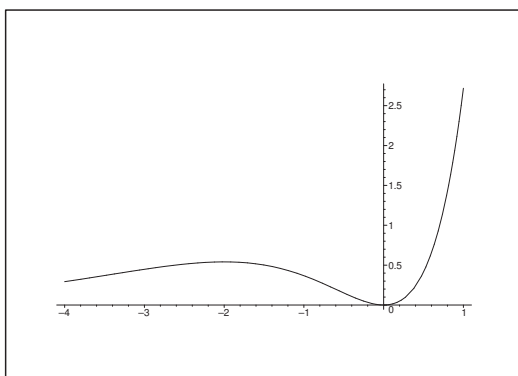
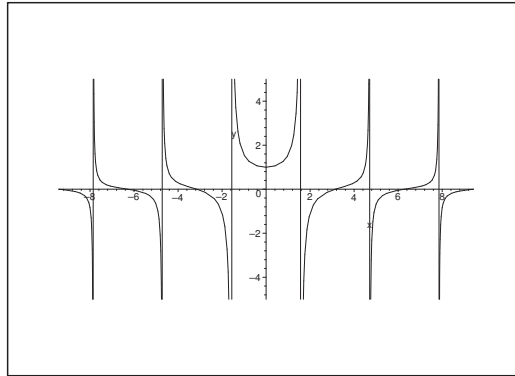

Figure 4: The graph of  $y = x^2 e^x$ .

- 5) The function  $y = x^2 e^x$  is defined and differentiable for every  $x \in \mathbb{R}$ , and

$$\frac{dy}{dx} = 2x e^x + x^2 e^x = x(x+2) e^x.$$



Figure 5: The graph of  $y = \frac{\tan x}{x}$ .

- 6) The function  $y = \frac{\tan x}{x}$  is defined and differentiable at least when

$$x \notin \{0\} \cup \left\{ \frac{\pi}{2} + p\pi \mid p \in \mathbb{Z} \right\}.$$

However, since both the numerator and the denominator are 0 for  $x = 0$ , we shall look closer at this point.

- a) When  $x \neq 0$  and  $x \neq \frac{\pi}{2} + p\pi$ ,  $p \in \mathbb{Z}$ , it follows from the rules of differentiation that

$$\begin{aligned} \frac{dy}{dx} &= \frac{1 + \tan^2 x}{x} - \frac{\tan x}{x^2} = \frac{x + x \tan^2 x - \tan x}{x^2} \\ &= \frac{x \cos^2 x + x \sin^2 x - \sin x \cos x}{x^2 \cos^2 x} = \frac{x - \sin x \cos x}{x^2 \cos^2 x}. \end{aligned}$$

- b) When  $x = 0$ , we get by the continuity that

$$\varphi(0) = \lim_{x \rightarrow 0} \frac{\tan x}{x} = \lim_{x \rightarrow 0} \frac{1}{\cos x} \cdot \frac{\sin x}{x} = 1 \cdot 1 = 1.$$

Then consider the difference quotient

$$\frac{\varphi(x) - \varphi(0)}{x - 0} = \frac{\frac{\tan x}{x} - 1}{x - 0} = \frac{\tan x - x}{x^2} = \frac{x^2 \varepsilon(x)}{x^2} = \varepsilon(x),$$

which converges towards 0 for  $x \rightarrow 0$ . Here we have used that the numerator  $\tan x - x$  is an odd function, and that the Taylor expansion starts with  $0 \cdot x$ , so the first true term is of the form  $c \cdot x^3 = x^2 \varepsilon(x)$ . We therefore conclude that the function is continuously defined and also differentiable at  $x = 0$  with the derivative  $\varphi'(0) = 0$ , which looks quite reasonable when we consider the figure.

**Example 1.2** Sketch the graphs of the following functions,

- 1)  $y = \cos 2x$ ,
- 2)  $y = \ln(-x)$ ,
- 3)  $y = \ln(e^x)$ ,
- 4)  $y = e^{-\ln \cot x}$ .

Write a programme in MAPLE, by which the graphs are constructed.

- A. Drawing of graphs and a MAPLE programme.
- D. Determine the domains and reduce the expressions, whenever it is possible.

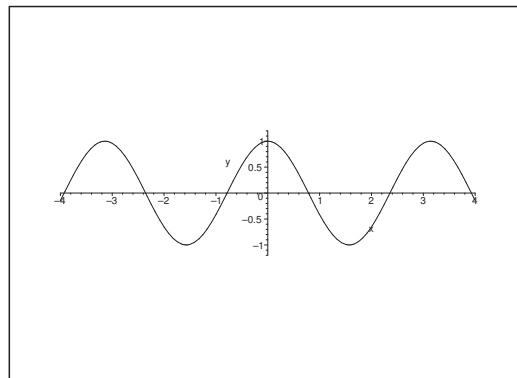

Figure 6: The graph of  $y = \cos 2x$ .

- I. 1) Usually there are several possibilities of writing a programme in MAPLE. Personally I prefer always to describe a function by using a parameter to describe the function. This may seem a little complicated, but it is actually the best way of doing it. Here, I suggest in the first case that we use

```
plot([t,cos(2*t),t=-4..4],x=-4..4,y=-1.2..1.2,
      scaling=constrained,color=black);
```

- 2) The function is defined for  $x < 0$ . Here we also have several possibilities of the MAPLE programme. My suggestion is

```
plot([t,ln(-t),t=-5..0],x=-5..1,y=-2..2,
      scaling=constrained,color=black);
```

- 3) The function is defined everywhere. By a reduction we get

$$y = \ln(e^x) = x,$$

so a simple MAPLE programme (which is not unique here either) is

```
plot([t,t,t=-1..1],scaling=constrained,color=black);
```

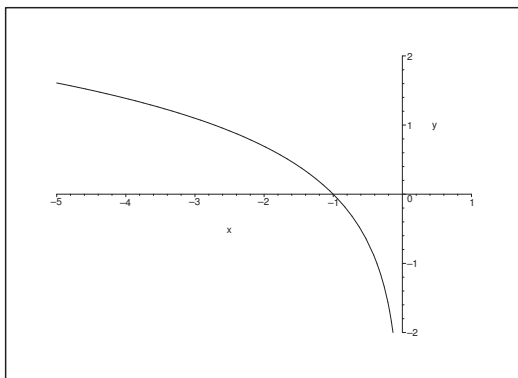
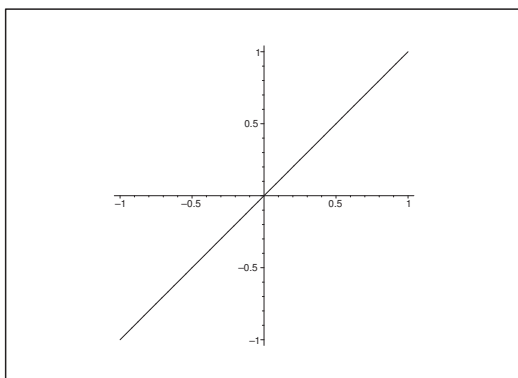
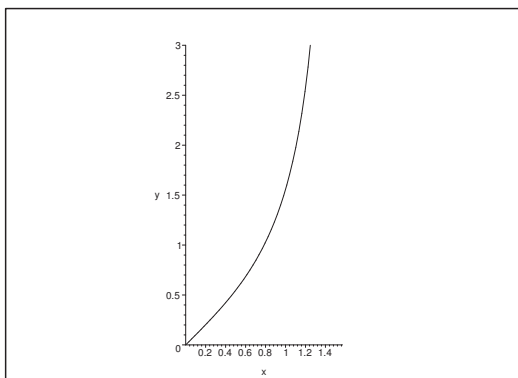
Figure 7: The graph of  $y = \ln(-x)$ ,  $x < 0$ .Figure 8: The graph of  $y = \ln(e^x) = x$ .Figure 9: The graph of  $y = e^{-\ln \cot x} = \tan x$  in the interval  $]0, \frac{\pi}{2}[$ .

4) The function  $y = e^{-\ln \cos x}$  is defined when  $\cot x > 0$ , i.e. for

$$x \in \bigcup_{p \in \mathbb{Z}} ]p\pi, p\pi + \frac{\pi}{2}[.$$

In this case the expression is reduced to

$$y = e^{-\ln \cot x} = \frac{1}{\cot x} = \tan x, \quad \tan x > 0.$$

In the interval  $]0, \frac{\pi}{2}[$  we can e.g. use the following MAPLE programme,

```
plot([t,tan(t),t=0..Pi/2-.1],x=0..Pi/2,y=0..3,
      scaling=constrained,color=black);
```

where we have cheated a little in order not to be troubled by the vertical line  $x = \frac{\pi}{2}$ . (This can also be removed by the command `discont=true`). Notice that one can get more of the graph by changing `y=0..3` to e.g. `y=0..4`.

Please click the advert

www.job.oticon.dk

**oticon**  
PEOPLE FIRST

Download free books at BookBooN.com

**Example 1.3** Reduce the following expressions:

1)  $y = \cos^2 x + \sin^2 x,$

2)  $y = \cos^2 x - \sin^2 x,$

3)  $y = e^{-\ln x},$

4)  $y = \ln(x e^x) - \ln x.$

**A.** Reduction of simple mathematical expressions.

**D.** Determine the domain and then apply high school mathematics.

**I.** 1) It is obvious that the expression is defined for every  $x \in \mathbb{R}$  and that

$$y = \cos^2 x + \sin^2 x = 1.$$

REMARK. It is very important for an engineering student to know that  $(x, y) = (\cos t, \sin t)$ ,  $t \in \mathbb{R}$ , is a parametric description of the *unit circle*, run through infinitely often. The most important movements are the straight movements and the circular movements.  $\diamond$

2) It should also be well-known that

$$y = \cos^2 x - \sin^2 x = \cos 2x, \quad \text{for every } x \in \mathbb{R}.$$

3) The function  $y = e^{-\ln x}$  is defined when  $\ln x$  is defined, i.e. for  $x > 0$ . In this case we get

$$y = e^{-\ln x} = \frac{1}{x}, \quad \text{for } x > 0.$$

REMARK. The trap is of course that one should believe that the function is defined if only  $x \neq 0$ . This is not true because we have not defined the logarithm of a negative number.  $\diamond$

4) The function  $y = \ln(e^x) - \ln x$  is defined for  $x > 0$ . In that case we have

$$y = \ln(x e^x) - \ln x = \ln x + \ln(e^x) - \ln x = x, \quad \text{for } x > 0.$$

**Example 1.4** Prove the following two formulæ of the derivative of the function

$$y = \tan x.$$

**A.** Prove that

$$\frac{d(\tan x)}{dx} = \frac{1}{\cos^2 x} = 1 + \tan^2 x.$$

**D.** Use the known rules of differentiation on  $\tan x = \frac{\sin x}{\cos x}$ .

I. When this is done we get for  $x \neq \frac{\pi}{2} + p\pi, p \in \mathbb{Z}$ , that

$$\begin{aligned} \frac{d(\tan x)}{dx} &= \frac{d}{dx} \left( \sin x \cdot \frac{1}{\cos x} \right) = \cos x \cdot \frac{1}{\cos x} + \sin x \cdot \left( -\frac{-\sin x}{\cos^2 x} \right) \\ &= 1 + \tan^2 x \\ &= 1 + \frac{\sin^2 x}{\cos^2 x} = \frac{\cos^2 x + \sin^2 x}{\cos^2 x} = \frac{1}{\cos^2 x}. \end{aligned}$$

**Example 1.5** For the two angles  $u$  and  $v$  we introduce the vectors

$$\mathbf{e} = (\cos u, \sin u) \quad \text{and} \quad \mathbf{f} = (\cos v, \sin v).$$

We can express the scalar product of  $\mathbf{e}$  and  $\mathbf{f}$  in two ways: Either by means of coordinates, or by taking the length of  $\mathbf{e}$  multiplied by the length (positive or negative) of the projection of  $\mathbf{f}$  onto the direction defined by  $\mathbf{e}$ . Apply this to prove an addition formula for trigonometric functions.

A. Derivation of an addition formula.

D. Consider a scalar product of two unit vectors in two different ways.

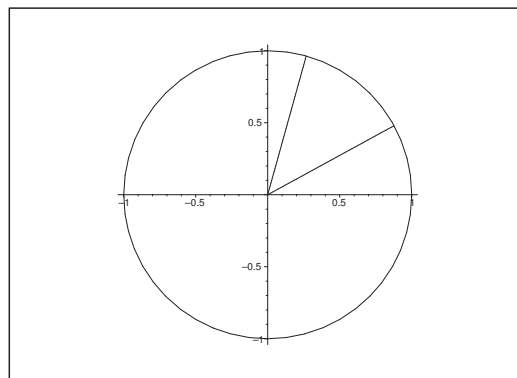

Figure 10: The vectors  $\mathbf{e}$  and  $\mathbf{f}$  with the angle  $v - u$  between them.

I. In rectangular coordinates the scalar product of the two vectors is given by

$$\begin{aligned} \mathbf{e} \cdot \mathbf{f} &= (\cos u, \sin u) \cdot (\cos v, \sin v) \\ &= \cos u \cdot \cos v + \sin u \cdot \sin v. \end{aligned}$$

The angle between the vectors  $\mathbf{e}$  and  $\mathbf{f}$  calculated from  $\mathbf{e}$  towards  $\mathbf{v}$  is given by  $v - u$ , hence the projection of the unit vector  $\mathbf{f}$  onto the direction given by  $\mathbf{e}$  is  $\cos(v - u)$ .

By an identification we therefore get

$$\cos(v - u) = \cos u \cdot \cos v + \sin u \cdot \sin v.$$



If we in this formula replace  $u$  by  $-u$ , we get

$$\cos(v + u) = \cos u \cdot \cos v - \sin u \cdot \sin v.$$

**Example 1.6** For two angles  $u$  and  $v$  we introduce the vectors

$$\mathbf{e} = (\cos u, \sin u) \quad \text{and} \quad \mathbf{f} = (\cos v, \sin v).$$

Prove an addition formula for trigonometric functions by first calculating the scalar product  $\hat{\mathbf{e}} \cdot \mathbf{f}$  in two ways: Either by means of rectangular coordinates, or by taking the product of the length of one of the vectors and the signed length of the projection of the second vector onto the direction of the first one.

A. A trigonometric addition formula.

D. First find the coordinates of the vector  $\hat{\mathbf{e}}$ . Then use the description above to calculate the scalar product in two different ways and identify the coordinates.

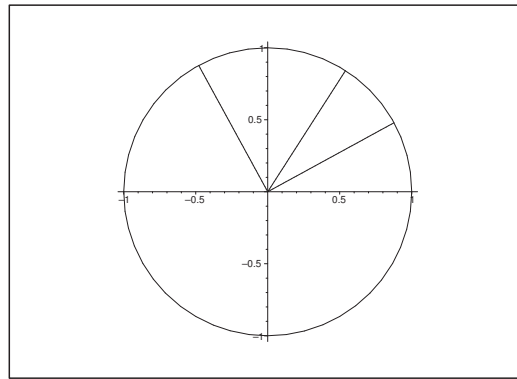

Figure 11: The vectors  $\mathbf{e}$  and  $\mathbf{f}$ , and the vector  $\hat{\mathbf{e}}$ , which is obtained by turning  $\mathbf{e}$  the angle  $\frac{\pi}{2}$ .

I. When  $\mathbf{e} = (\cos u, \sin u)$ , we get

$$\hat{\mathbf{e}} = (-\sin u, \cos u),$$

(interchange the coordinates and then change the sign on the first coordinate). Then the inner product becomes

$$\hat{\mathbf{e}} \cdot \mathbf{f} = (-\sin u, \cos u) \cdot (\cos v, \sin v) = \cos u \cdot \sin v - \sin u \cdot \cos v.$$

On the other hand, the signed angle between  $\hat{\mathbf{e}}$  and  $\mathbf{f}$  is given by  $v - u - \frac{\pi}{2}$ , i.e. the projection of the unit vector  $\mathbf{f}$  onto the line determined by the direction  $\hat{\mathbf{e}}$  is

$$\cos\left(v - u - \frac{\pi}{2}\right) = \cos\left(\frac{\pi}{2} - (v - u)\right) = \sin(v - u).$$

When these two expressions are identified we get

$$\sin(v - u) = \sin v \cdot \cos u - \cos v \cdot \sin u.$$

Finally, when  $u$  is replaced by  $-u$  we get

$$\sin(u + v) = \sin u \cdot \cos v + \cos u \cdot \sin v,$$

and we have proved the addition formula.

**Example 1.7** *Prove that*

$$\tan \frac{v}{2} = \frac{\sin v}{1 + \cos v}, \quad v \neq \pi + 2p\pi.$$

- A. Proof of a trigonometric formula.
- D. Express e.g. the right hand side by half of the angle and reduce.
- I. First note that both sides of the equality sign is defined, if and only if

$$v \neq \pi + 2p\pi, \quad p \in \mathbb{Z}.$$

Please click the advert

**CHALLENGE YOURSELF**

**WWW.STUDYINSWEDEN.SE**

**Si.**  
Swedish Institute

Today's job market values ambitious, innovative, perceptive team players. Swedish universities foster these qualities through a forward-thinking culture where you're close to the latest ideas and global trends.

Whatever your career goals may be, studying in Sweden will give you valuable skills and a competitive advantage for your future. [www.studyinsweden.se](http://www.studyinsweden.se)

Then calculate the right hand side by changing variable to the half angle,

$$\frac{\sin v}{1 + \cos v} = \frac{2 \sin \frac{v}{2} \cos \frac{v}{2}}{1 + \cos^2 \frac{v}{2} - \sin^2 \frac{v}{2}} = \frac{2 \sin \frac{v}{2} \cdot \cos \frac{v}{2}}{2 \cos^2 \frac{v}{2}} = \frac{\sin \frac{v}{2}}{\cos \frac{v}{2}} = \tan \frac{v}{2}.$$

**Example 1.8** Sketch in the same coordinate system the functions  $f(x) = a^x$  for  $a = 2$ ,  $a = 3$  and  $a = 4$ . It should in particular be indicated when some graph lies above another one.

A. Graph sketches of exponentials.

D. Write a suitable MAPLE programme.

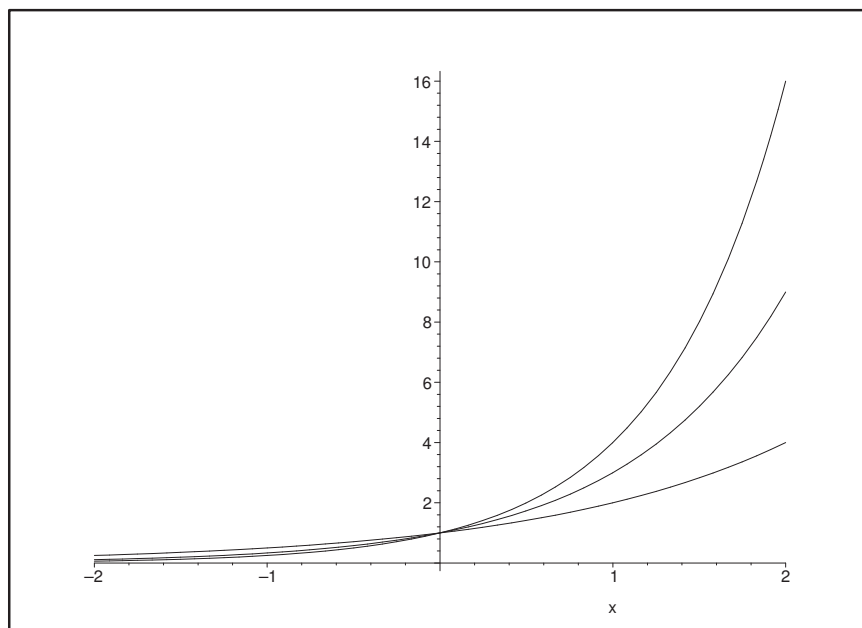

Figure 12: The graphs of  $f(x) = a^x$  for  $a = 2, 3$  and  $4$ . Different scales on the axes.

I. Here I have used the following MAPLE programme:

```
plot({2^x, 3^x, 4^x}, x=-2..2, color=black);
```

Every graph goes through  $(0, 1)$ . To the left of the  $y$ -axis we have

$$4^x < 3^x < 2^x, \quad \text{for } x < 0,$$

and to the right of the  $y$ -axis we have instead

$$2^x < 3^x < 4^x, \quad \text{for } x > 0.$$

**Example 1.9** Sketch in the same coordinate system the functions  $f(x) = x^\alpha$ ,  $x \geq 0$ , for  $\alpha = \frac{1}{2}$ ,  $\alpha = 2$  and  $\alpha = 3$ . Indicate in particular when some graph lies above another one.

- A. Graph sketches of power functions.  
 D. Write a suitable MAPLE programme.

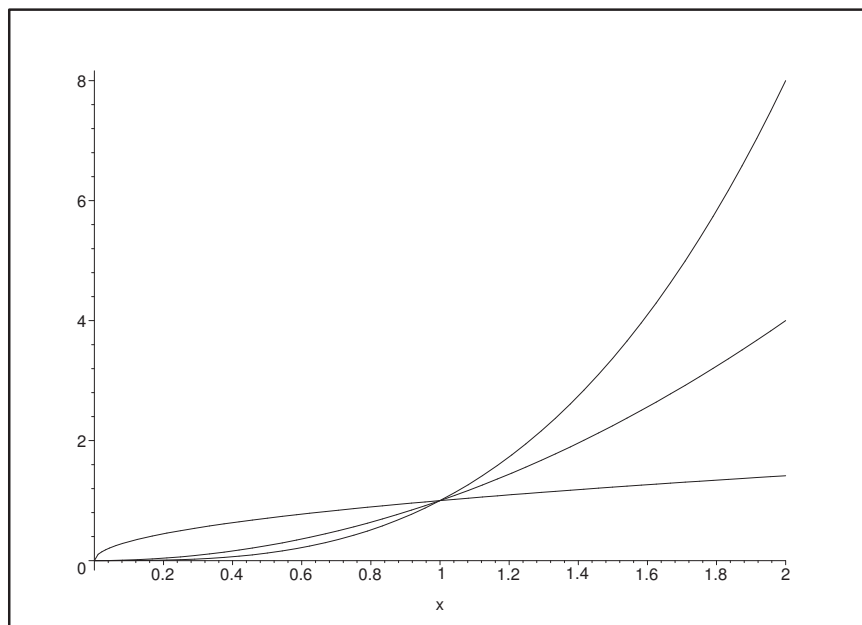

Figure 13: The graphs of  $f(x) = x^\alpha$ ,  $x \geq 0$ , for  $\alpha = \frac{1}{2}$ , 2 and 3. Different scales on the axes.

- I. The following MAPLE programme has been applied:

```
plot({sqrt(x), x^2, x^3}, x=0..2, color=black);
```

Every graph goes through  $(0, 0)$  and  $(1, 1)$ . In the interval  $]0, 1[$  we have

$$x^3 < x^2 < \sqrt{x}, \quad \text{for } x \in ]0, 1[,$$

and when  $x > 1$ , we have instead

$$\sqrt{x} < x^2 < x^3, \quad \text{for } x > 1.$$

**Example 1.10** Given three positive numbers  $a$ ,  $r$  and  $s$  such that

$$a^{r+s} = 128, \quad a^{r-s} = 8, \quad a^{rs} = 1024.$$

Find the numbers  $a$ ,  $r$  and  $s$ .

- A.** Three nonlinear equations in three unknowns.
- D.** Apply the logarithm on all three equations and solve the new equations.
- I.** Since  $128 = 2^7$  and  $8 = 2^3$  and  $1024 = 2^{10}$ , we get by taking the logarithm of the three given equations that

$$\begin{cases} (r+s) \ln a = 7 \ln 2, \\ (r-s) \ln a = 3 \ln 2, \\ rs \ln a = 10 \ln 2. \end{cases}$$

It follows from the first two equations by an addition and a subtraction, etc. that

$$\begin{cases} r \ln a = 5 \ln 2, \\ s \ln a = 2 \ln 2. \end{cases}$$

When these expressions are inserted into the last equation we get

$$10 \ln 2 = rs \ln a = s(r \ln a) = s \cdot 5 \ln 2, \quad \text{i.e. } s = 2;$$

$$10 \ln 2 = rs \ln a = r(s \ln a) = r \cdot 2 \ln 2. \quad \text{i.e. } r = 5.$$

Finally, it follows e.g. from  $r \ln a = 5 \ln 2$  and  $r = 5$  that  $\ln a = \ln 2$ , thus  $a = 2$ . Hence we have found that

$$a = 2, \quad r = 5, \quad s = 2.$$

- C.** CHECK. When  $a = 2$  and  $r = 5$  and  $s = 2$ , we get by insertion into the original equations that

$$\begin{aligned} a^{r+s} &= 2^{5+2} = 2^7 = 128, \\ a^{r-s} &= 2^{5-2} = 2^3 = 8, \\ a^{rs} &= 2^{5 \cdot 2} = 2^{10} = 1024. \end{aligned}$$

We see that all three equations are fulfilled.

**Example 1.11** Given three positive numbers  $a$  and  $b$  and  $r$  such that

$$(ab)^r = 3, \quad a^{-r} = \frac{1}{2}, \quad a^{\frac{1}{r}} = 16.$$

Find the numbers  $a$  and  $b$  and  $r$ .

- A.** Three nonlinear equations in three unknowns, which all must be positive.
- D.** Take the logarithm and solve the new equations.
- I.** By taking the logarithm of the three equations we get

$$\begin{cases} \ln 3 = r \ln(ab) = r \ln a + r \ln b, \\ \ln \frac{1}{2} = -r \ln a, \\ \ln 16 = \frac{1}{r} \ln a, \end{cases}$$

which we rewrite as

$$\begin{cases} r \ln a + r \ln b = \ln 3, \\ r \ln a = \ln 2, \\ \frac{1}{r} \ln a = \ln 16 = 4 \ln 2. \end{cases}$$

When we divide the latter equation into the former equation, we get

$$\frac{r \ln a}{\frac{1}{r} \ln a} = r^2 = \frac{\ln 2}{4 \ln 2} = \frac{1}{4}.$$

Since  $r > 0$  according to the assumptions, we get

$$r = \frac{1}{2},$$

hence by an insertion into the second equation,

$$\frac{1}{2} \ln a = \ln 2, \text{ hvoraf } a = 4.$$

Please click the advert

## Turning a challenge into a learning curve. Just another day at the office for a high performer.

### Accenture Boot Camp – your toughest test yet

Choose Accenture for a career where the variety of opportunities and challenges allows you to make a difference every day. A place where you can develop your potential and grow professionally, working alongside talented colleagues. The only place where you can learn from our unrivalled experience, while helping our global clients achieve high performance. If this is your idea of a typical working day, then Accenture is the place to be.

It all starts at Boot Camp. It's 48 hours that will stimulate your mind and enhance your career prospects. You'll spend time with other students, top Accenture Consultants and special guests. An inspirational two days

packed with intellectual challenges and activities designed to let you discover what it really means to be a high performer in business. We can't tell you everything about Boot Camp, but expect a fast-paced, exhilarating

and intense learning experience. It could be your toughest test yet, which is exactly what will make it your biggest opportunity.

Find out more and apply online.

Visit [accenture.com/bootcamp](https://www.accenture.com/bootcamp)

• Consulting • Technology • Outsourcing

  
High performance. Delivered.



Finally we get from the first equation that

$$\ln 2 + \frac{1}{2} \ln b = \ln 3,$$

hence

$$\ln b = 2\{\ln 3 - \ln 2\} = \ln \frac{9}{4}, \quad \text{dvs. } b = \frac{9}{4}.$$

As a conclusion the solution is

$$a = 4, \quad b = \frac{9}{4}, \quad r = \frac{1}{2}.$$

**C. TEST.** By insertion of these values into the original equations we get

$$\begin{aligned} (ab)^r &= \left(4 \cdot \frac{9}{4}\right)^{\frac{1}{2}} = 9^{\frac{1}{2}} = 3, \\ a^{-r} &= 4^{-\frac{1}{2}} = 2^{-1} = \frac{1}{2}, \\ a^{\frac{1}{r}} &= 4^2 = 16. \end{aligned}$$

It is seen that all three original equations are fulfilled.

**REMARK.** It can be proved that if one does not require that  $a$  and  $b$  and  $r$  are all positive, then we get another solution,

$$a = \frac{1}{4}, \quad b = \frac{4}{9}, \quad r = -\frac{1}{2}.$$

The proof of this claim is left to the reader.  $\diamond$ .

**Example 1.12** *Prove the three power rules*

$$a^{r+s} = a^r \cdot a^s, \quad (ab)^r = a^r \cdot b^r, \quad (a^r)^s = a^{rs},$$

*by assuming the logarithmic rules.*

**A.** We shall prove three rules for power functions, where we assume that the rules of logarithm hold, and that the function  $\ln : \mathbb{R}_+ \rightarrow \mathbb{R}$  is continuous and strictly increasing.

**D.** Set up the rules of logarithm and derive the power rules.

**I.** We can use the following three rules,

**I**  $\ln(ab) = \ln a + \ln b$ , for  $a, b > 0$ .

**II**  $\ln\left(\frac{a}{b}\right) = \ln a - \ln b$ , for  $a, b > 0$ .

**III**  $\ln(a^r) = r \ln a$ , for  $a > 0$  and  $r \in \mathbb{R}$ .

1) By applying rule **III** twice and at the last equality using rule **I** we get

$$\begin{aligned}\ln(a^{r+s}) &= (r+s)\ln a = r\ln a + s\ln a \\ &= \ln(a^r) + \ln(a^s) = \ln(a^r \cdot a^s).\end{aligned}$$

Since  $\ln$  is one-to-one, we get by the exponential that

$$a^{r+s} = a^r \cdot a^s.$$

2) Analogously we get by applying the rules **III**, **I**, **III**, **I** that

$$\begin{aligned}\ln((ab)^r) &= r \cdot \ln(ab) = r\{\ln a + \ln b\} = r\ln a + r\ln b \\ &= \ln(a^r) + \ln(b^r) = \ln(a^r \cdot b^r).\end{aligned}$$

Since  $\ln$  is one-to-one we get by the exponential that

$$(ab)^r = a^r b^r.$$

3) Finally we get by using rule **III** at every equality sign that

$$\ln((a^r)^s) = s \ln(a^r) = rs \ln a = \ln(a^{rs}).$$

Since  $\ln$  is one-to-one we get by the exponential that

$$(a^r)^s = a^{rs}.$$

**Example 1.13** *Given a positive number  $a$  and a natural number  $n$ . Then  $a^n$  can be defined in two ways: Either as the product of  $a$  with itself  $n$  times, or by  $a^n = e^{n \ln a}$ . Explain why the two definitions give the same result.*

**A.** Two apparently different definitions should give the same.

**D.** Use the rules of the logarithm.

**I.** Since

$$\ln(ab) = \ln a + \ln b \quad \text{for } a, b > 0,$$

we get for  $b = a$ ,

$$\ln(a^2) = \ln(a \cdot a) = 2 \ln a,$$

hence the claim is true for  $n = 1$  and for  $n = 2$ , where  $a > 0$  is any number. This indicates that we should try

INDUCTION. Assume that

$$\ln(a^n) = n \ln a \quad \text{for some } n \in \mathbb{N}.$$

This assumption has been proved to be true for  $n = 1$  and for  $n = 2$ .

Then we get for the successor,

$$\ln(a^{n+1}) = \ln(a^n \cdot a) = \ln(a^n) + \ln a = n \ln a + \ln a = (n+1) \ln a,$$

and we conclude that the formula follows by induction.

We have now proved that

$$\ln(a^n) = n \ln a = \ln(e^{n \ln a}).$$

Since  $\ln : \mathbb{R}_+ \rightarrow \mathbb{R}$  is bijective, we have

$$a^n = a \cdots a = e^{n \ln a},$$

and it follows that the two definitions agree for every  $n \in \mathbb{N}$ .

**Example 1.14** Investigate in each of the following cases if the claim is correct or wrong:

- 1)  $(xy)^z = xy^z$ ,
- 2)  $x^y = e^{y \ln x}$ ,
- 3)  $\ln(a-b) = \frac{\ln a}{\ln b}$ ,
- 4)  $x^{y+z} = x^y + x^z$ ,
- 5)  $\sin(x+y) = \sin x + \sin y$ ,
- 6)  $(a+b)^2 = a^2 + b^2$ ,
- 7)  $\sin v = 2 \cos^2 \frac{v}{2} - 1$ ,
- 8)  $\int x^\alpha dx = \frac{x^{\alpha+1}}{\alpha+1}$ ,
- 9)  $\int 2^x dx = \frac{2^{x+1}}{x+1}$ ,
- 10)  $\int \frac{1}{\sin^2 x} dx = -\cot x$ .

**A.** The formulation of this example is on purpose very sloppy, because this is more or less how the students' exercises are formulated without any "proof". We shall find out if some given "formulae" are correct or not. The solutions will not be too meticulous, because that would demand a lot more.

**D.** If one of the formulae is correct, it should of course be proved, and its domain should be specified.

If some formula is wrong, one should give a counterexample. This part is a little tricky because the formula may be right for carefully chosen  $x$ ,  $y$  and  $z$ . In particular, one cannot give some general guidelines for how to do it.

I. 1) The claim is in general wrong. If we e.g. choose  $x = y = z = 2$ , we get

$$(xy)^z = (2 \cdot 2)^2 = 16, \quad xy^z = 2 \cdot 2^2 = 8 \neq 16 = (xy)^z.$$

Notice however that the formula is correct if  $z = 1$ , or if  $x = 1$  (or  $x = 0$ ).

2) The claim is true for  $x > 0$ .

3) The claim is wrong. First notice that its *potential* domain is given by  $0 < b < a$ . If we here e.g. choose  $b = a - 1$  for any  $a > 1$ , we get

$$\ln(a - b) = \ln 1 = 0 \quad \text{and} \quad \frac{\ln a}{\ln b} \neq 0, \quad \text{when } b \neq 1.$$

4) The claim is wrong. Choosing e.g.  $x = y = z = 1$ , we get

$$x^{y+z} = 1^{1+1} = 1 \quad \text{and} \quad x^y + x^z = 1^1 + 1^1 = 2 \neq 1 = x^{y+z}.$$

It follows by continuity that the formula is not correct in some open domain containing  $(1, 1, 1)$ .

5) The claim is wrong. If we choose  $x = y = \frac{\pi}{2}$  we get

$$\sin(x + y) = \sin \pi = 0 \quad \text{and} \quad \sin x + \sin y = 1 + 1 = 2 \neq 0 = \sin(x + y).$$

Please click the advert





it's an **interesting** world

## Get under the skin of it.

**Graduate opportunities**  
**Cheltenham | £24,945 + benefits**

One of the UK's intelligence services, GCHQ's role is two-fold: to gather and analyse intelligence which helps shape Britain's response to global events, and, to provide technical advice for the protection of Government communication and information systems. In doing so, our specialists – in IT, internet, engineering, languages, information assurance, mathematics and intelligence – get well beneath the surface of global affairs. If you thought the world was an interesting place, you really ought to explore our world of work.

[www.careersinbritishintelligence.co.uk](http://www.careersinbritishintelligence.co.uk)

Applicants must be British citizens. GCHQ values diversity and welcomes applicants from all sections of the community. We want our workforce to reflect the diversity of our work.







6) The claim is wrong when both  $a \neq 0$  and  $b \neq 0$ . In fact,

$$(a + b)^2 = a^2 + b^2 + 2ab,$$

and we see that the additional term  $2ab \neq 0$ , when  $a \neq 0$  and  $b \neq 0$ .

REMARK. A very frequent error made by the students is to put  $(a + b)^2$  equal to  $a^2 + b^2$ , which is *not* correct.  $\diamond$

7) The claim is wrong. The left hand side  $\sin v$  is an *odd* function  $\neq 0$ , and the right hand side is an *even* function  $\neq 0$ . The only function, which is both odd and even is 0.

8) This claim is correct for  $\alpha \neq -1$ . In fact,

$$\frac{d}{dx} \left( \frac{x^{\alpha+1}}{\alpha+1} \right) = \frac{\alpha+1}{\alpha+1} \cdot x^\alpha = x^\alpha.$$

When  $\alpha = -1$ , the right hand side is not defined (never divide by 0). It is well-known that

$$\int x^{-1} dx = \int \frac{1}{x} dx = \ln|x|, \quad \text{for } x \neq 0.$$

9) The claim is wrong which can be seen by at small test,

$$\begin{aligned} \frac{d}{dx} \left\{ \frac{2^{x+1}}{x+1} \right\} &= \frac{d}{dx} \left\{ \frac{e^{(x+1)\ln 2}}{x+1} \right\} \\ &= \frac{\ln 2 \cdot e^{(x+1)\ln 2}}{x+1} - \frac{e^{(x+1)\ln 2}}{(x+1)^2} \\ &= \frac{2^{x+1}}{(x+1)^2} \{(x+1)\ln 2 - 1\} \neq 2^x. \end{aligned}$$

10) The claim is correct for  $x \neq p\pi$ ,  $p \in \mathbb{Z}$ . In fact, we get by a test

$$\frac{d}{dx} \{-\cot x\} = -\frac{d}{dx} \left\{ \frac{\cos x}{\sin x} \right\} = -\left\{ \frac{-\sin^2 - \cos^2 x}{\sin^2 x} \right\} = \frac{1}{\sin^2 x}.$$

**Example 1.15** *Prove that*

1)  $\cos 2x = 2 \cos^2 x - 1 = 1 - 2 \sin^2 x,$

2)  $\sin 2x = 2 \sin x \cos x.$

**A.** Two simple applications of the rules of calculations.

**D.** Apply the rules with  $y = x$  and the sign +.

**I.** We shall also need the trigonometric fundamental equation

$$\cos^2 x + \sin^2 x = 1.$$

1) When  $y = x$ , we get by the rules of calculations that

$$\begin{aligned}\cos 2x &= \cos(x+x) = \cos x \cdot \cos x - \sin x \cdot \sin x \\ &= \cos^2 - \sin^2 \\ &= \cos^2 x - (1 - \cos^2 x) = 2 \cos^2 x - 1 \\ &= (1 - \sin^2 x) - \sin^2 = 1 - 2 \sin^2 x.\end{aligned}$$

2) Analogously,

$$\sin 2x = \sin(x+x) = \sin x \cdot \cos x + \cos x \cdot \sin x = 2 \sin x \cdot \cos x.$$

**Example 1.16** Let  $x_0(t)$  be the solution of the differential equation

$$\frac{dx}{dt} + 2x = a,$$

for which

$$x(0) = 5 \quad \text{and} \quad x(t) \rightarrow 100 \quad \text{for } t \rightarrow \infty.$$

Find  $x_0(t)$ .

Does there exist a solution  $x(t)$ , for which

$$x(t) \rightarrow \infty \quad \text{for } t \rightarrow \infty?$$

**A.** A linear, inhomogeneous differential equation of first order.

**D.** Start by finding the complete solution. Even though it is possible here to apply the solution formula, we shall choose the variant, in which one multiplies by the integrating factor  $e^{2t}$  and reduces.

**I.** When the equation is multiplied by  $e^{2t}$ , we get

$$a e^{2t} = e^{2t} \frac{dx}{dt} + 2e^{2t} \cdot x = \frac{d}{dt} \{e^{2t} x\},$$

hence by an integration,

$$e^{2t} x = \frac{a}{2} e^{2t} + c, \quad \text{dvs.} \quad x = \frac{a}{2} + c \cdot e^{-2t}.$$

When the conditions are inserted into the complete solution we get

$$x(0) = 5 = \frac{a}{2} + c \quad \text{and} \quad x(t) \rightarrow \frac{a}{2} = 100 \quad \text{for } t \rightarrow \infty,$$

hence  $a = 200$  and  $c = -95$ . The searched solution is then

$$x_0(t) = \frac{a}{2} + c \cdot e^{-2t} = 100 - 95 \cdot e^{-2t}.$$

Finally, since

$$x(t) = \frac{a}{2} + c \cdot e^{-2t} \rightarrow \frac{a}{2} \quad t \rightarrow \infty,$$

there does not exist any solution for which  $x(t) \rightarrow \infty$  for  $t \rightarrow \infty$ .



**Example 1.17** Calculate the integral  $\int \cos x \cdot \sin x \, dx$  in three ways:

- 1) Express the integrand by  $\sin 2x$ .
- 2) Move  $\sin x$  under the  $d$ -sign.
- 3) Move  $\cos x$  under the  $d$ -sign.

**A.** Trigonometric integral calculated in three ways.

**D.** Follow the description.

**I.** 1) Since  $\cos x \cdot \sin x = \frac{1}{2} \sin 2x$ , we get

$$\int \cos x \cdot \sin x \, dx = \frac{1}{2} \int \sin 2x \, dx = -\frac{1}{4} \cos 2x + c_1.$$

2) Since  $\sin x \, dx = -d \cos x$ , we get

$$\int \cos x \cdot \sin x \, dx = - \int \cos x \, d \cos x = -\frac{1}{2} \cos^2 x + c_2.$$

3) Since  $\cos x \, dx = d \sin x$ , we get

$$\int \cos x \cdot \sin x \, dx = \int \sin x \, d \sin x = \frac{1}{2} \sin^2 x + c_3.$$

Please click the advert



**Brain power**

By 2020, wind could provide one-tenth of our planet's electricity needs. Already today, SKF's innovative know-how is crucial to running a large proportion of the world's wind turbines.

Up to 25 % of the generating costs relate to maintenance. These can be reduced dramatically thanks to our systems for on-line condition monitoring and automatic lubrication. We help make it more economical to create cleaner, cheaper energy out of thin air.

By sharing our experience, expertise, and creativity, industries can boost performance beyond expectations. Therefore we need the best employees who can meet this challenge!

**The Power of Knowledge Engineering**

Plug into The Power of Knowledge Engineering.  
Visit us at [www.skf.com/knowledge](http://www.skf.com/knowledge)

**SKF**

REMARK. It follows that

$$-\frac{1}{4} \cos 2x = -\frac{1}{4} \{\cos^2 x - \sin^2 x\} = -\frac{1}{2} \cos^2 x + \frac{1}{4} = \frac{1}{2} \sin^2 x - \frac{1}{4},$$

so the three integrals  $-\frac{1}{4} \cos 2x$ ,  $-\frac{1}{2} \cos^2 x$  and  $\frac{1}{2} \sin^2 x$  only differ from each other by a constant.  
 $\diamond$

**Example 1.18** Draw an isosceles triangle of side length 1 and add one of its projections of a corner onto the opposite side. Estimate from this figure sinus and cosine to  $\frac{\pi}{6}$  and  $\frac{\pi}{3}$ . Find in a similar way, sinus, cosine and tangens of  $\frac{\pi}{4}$ .

A. Sinus and cosine of special chosen angles by considering a figure.

D. Draw a figure and find the values.

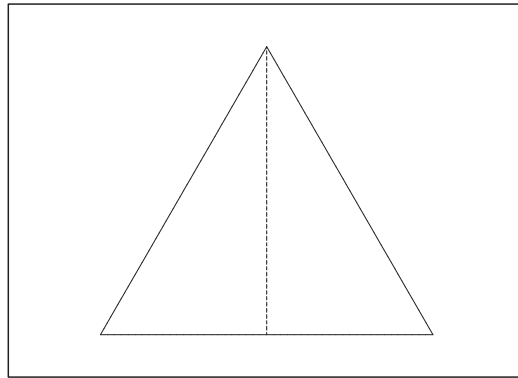

Figure 14: The isosceles triangle of side length 1.

I. The angles of an isosceles triangle are all  $\frac{\pi}{3}$ , and the additional line halves the corresponding angle to  $\frac{\pi}{6}$ .

The additional line is now a smaller side in a right-angled triangle where the larger side has length 1, and where the closer one of the smaller sides has length  $\frac{1}{2}$ . Then

$$\cos\left(\frac{\pi}{3}\right) = \text{length of the closer one of the smaller sides} = \frac{1}{2},$$

$$\cos\left(\frac{\pi}{6}\right) = \text{length of the other one of the smaller sides} = \sqrt{1 - \left(\frac{1}{2}\right)^2} = \frac{\sqrt{3}}{2}.$$

$$\sin\left(\frac{\pi}{3}\right) = \text{length of the other one of the smaller sides} = \frac{\sqrt{3}}{2}.$$

$$\sin\left(\frac{\pi}{6}\right) = \text{length of the closer one of the smaller sides} = \frac{1}{2}.$$

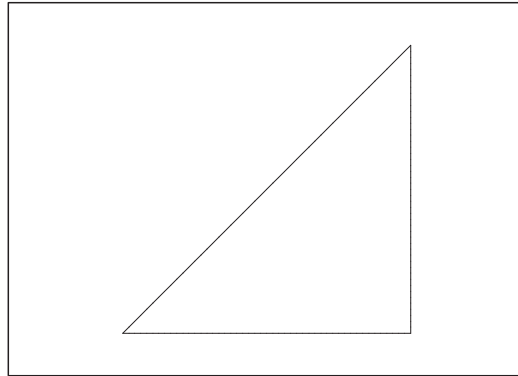

Figure 15: A right-angled triangle where the smaller sides have length 1.

The corresponding rectangular triangle of angle  $\frac{\pi}{4}$  has equal smaller sides, e.g. of length 1. Then the hypotenuse has the length  $\sqrt{1^2 + 1^2} = \sqrt{2}$ , from which

$$\cos\left(\frac{\pi}{4}\right) = \sin\left(\frac{\pi}{4}\right) = \frac{1}{\sqrt{2}},$$

and

$$\tan\frac{\pi}{4} = \frac{\sin\left(\frac{\pi}{4}\right)}{\cos\left(\frac{\pi}{4}\right)} = 1,$$

which can also be found directly, because the two smaller sides are of equal length.

**Example 1.19** Write the formula for the differentiation of a composite function. Then calculate the derivatives of the following functions:

- 1)  $y = \cos 2x$ ,
- 2)  $y = e^{\sin x}$ ,
- 3)  $y = e^{\ln x}$ ,
- 4)  $y = e^{\sqrt{x}}$ .

**A.** Differentiation of a composite function.

**D.** Follow the text. In (3) one should first reduce.

**I.** When  $F(x) = f(g(x))$ , where  $f$  and  $g$  are differentiable functions, then it is well-known that

$$F'(x) = f'(g(x)) \cdot g'(x).$$

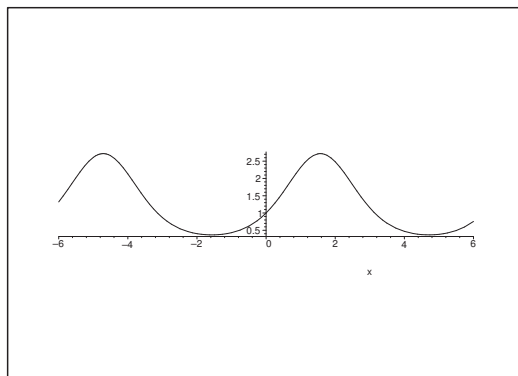
Figure 16: The graph of  $e^{\sin x}$ .

1) In this case we get

$$\frac{dy}{dx} = -\sin(2x) \cdot 2 = -2 \sin 2x.$$

2) Here we get analogously

$$\frac{dy}{dx} = e^{\sin x} \cdot \cos x = \cos x \cdot e^{\sin x}.$$

3) The function is only defined for  $x > 0$ , where

$$y = e^{\ln x} = x, \quad \text{for } x > 0,$$

så  $\frac{dy}{dx} = 1$  for  $x > 0$ .

ALTERNATIVELY,

$$\frac{dy}{dx} = e^{\ln x} \cdot \frac{1}{x} = x \cdot \frac{1}{x} = 1.$$

4) The function is defined for  $x \geq 0$  and it is differentiable for  $x > 0$ . Here,

$$\frac{dy}{dx} = e^{\sqrt{x}} \cdot \left( \frac{1}{2} \cdot \frac{1}{\sqrt{x}} \right) = \frac{1}{2\sqrt{x}} e^{\sqrt{x}}.$$

**Example 1.20** Write the formulæ for differentiation of a product and a quotient. Then calculate the derivatives of the following functions:

$$1) y = x \ln x - x,$$

$$2) y = 2 \sin x \cdot \cos x,$$

$$3) y = \frac{1}{x},$$

$$4) y = \tan x = \frac{\sin x}{\cos x}.$$

In the latter case one should derive both formulæ for the derivative of  $\tan$ .

A. Differentiation.

D. Follow the description of the text.

I. Assume that  $f$  and  $g$  are differentiable, and let  $F(x) = f(x)g(x)$ . Then

$$F'(x) = f'(x) \cdot g(x) + f(x) \cdot g'(x).$$

Assume that  $f$  and  $g$  are differentiable, and let  $F(x) = \frac{f(x)}{g(x)}$ , where furthermore  $g(x) \neq 0$ . Then

$$F'(x) = \frac{f'(x)}{g(x)} - f(x) \cdot \frac{g'(x)}{g(x)^2} = \frac{f'(x)g(x) - f(x)g'(x)}{g(x)^2}.$$

## Trust and responsibility

NNE and Pharmaplan have joined forces to create NNE Pharmaplan, the world's leading engineering and consultancy company focused entirely on the pharma and biotech industries.

Inés Aréizaga Esteva (Spain), 25 years old  
Education: Chemical Engineer

– You have to be proactive and open-minded as a newcomer and make it clear to your colleagues what you are able to cope. The pharmaceutical field is new to me. But busy as they are, most of my colleagues find the time to teach me, and they also trust me. Even though it was a bit hard at first, I can feel over time that I am beginning to be taken seriously and that my contribution is appreciated.

Please click the advert



NNE Pharmaplan is the world's leading engineering and consultancy company focused entirely on the pharma and biotech industries. We employ more than 1500 people worldwide and offer global reach and local knowledge along with our all-encompassing list of services.  
[nnepharmaplan.com](http://nnepharmaplan.com)

nne pharmaplan®

The latter formula is preferred in high school and it is also mostly found in tables. However, the former formula is in practice often more convenient to use. It is derived by considering the quotient

$$\frac{f(x)}{g(x)} = f(x) \cdot \frac{1}{g(x)}$$

as a product, where

$$\frac{d}{dx} \left( \frac{1}{g(x)} \right) = -\frac{g'(x)}{g(x)^2}.$$

This product is again obtained by composing  $h(y) = \frac{1}{y}$  and  $g(x)$  to  $H(x) = h(g(x))$ , then apply the rule of differentiation of a composite function, and that  $h'(y) = -\frac{1}{y^2}$ .

REMARK 1. The reason why

$$(1) \quad \frac{d}{dx} \left( \frac{f(x)}{g(x)} \right) = \frac{f'(x)}{g(x)} - f(x) \cdot \frac{g'(x)}{g(x)^2}$$

often is more convenient to use is that the first term  $\frac{f'(x)}{g(x)}$  is simpler than the corresponding term  $\frac{f'(x)g(x)}{g(x)^2}$  in the formula known from high school. The preference in most places of this high school formula is due to the fact that it is more “symmetric” than (1), thus easier to remember.  $\diamond$

1) A differentiation of  $y = x \cdot \ln x - x$  gives by the rule above that

$$\frac{dy}{dx} = 1 \cdot \ln x + x \cdot \frac{1}{x} - 1 = \ln x.$$

REMARK 2. From this we also derive the important result,

$$\int \ln x \, dx = x \cdot \ln x - x. \quad \diamond$$

2) A differentiation of  $y = 2 \sin x \cdot \cos x = \sin 2x$  gives by the rule of calculation above that

$$\frac{dy}{dx} = 2 \cdot \cos^2 x - 2 \cdot \sin^2 x = 2 \cos 2x,$$

which can also be found directly by a rewriting.

3) Putting  $f(x) = 1$  and  $g(x) = x$  we get

$$\frac{dy}{dx} = -\frac{1}{x^2}.$$

REMARK 3. This is actually a circular argument. We have above *assumed* this rule when we derived this result! In the correct proof one has to go back to the difference quotient (where we assume that  $x \neq 0$  and  $x + \Delta x \neq 0$ ),

$$\frac{\frac{1}{x + \Delta x} - \frac{1}{x}}{\Delta x} = \frac{-\Delta x}{\Delta x \cdot (x + \Delta x)x} = -\frac{1}{x(x + \Delta x)} \rightarrow -\frac{1}{x^2} \quad \text{for } \Delta x \rightarrow 0. \quad \diamond$$

4) Let  $f(x) = \sin x$  and  $g(x) = \cos x$ , and assume that  $x \neq \frac{\pi}{2} + p \cdot \pi$ ,  $p \in \mathbb{Z}$ . Then we get by (1) that

$$\begin{aligned} \frac{d}{dx} \tan x &= \cos x \cdot \frac{1}{\cos x} - \frac{\sin x \cdot (-\sin x)}{\cos x} = 1 + \tan^2 x \\ &= \frac{\cos^2 x - \sin x(-\sin x)}{\cos^2} = \frac{1}{\cos^2 x}. \end{aligned}$$

**Example 1.21** Write the addition formulæ of  $\sin(x \pm y)$  and  $\cos(x \pm y)$ . Then derive formulæ for  $\sin 2x$  and  $\cos 2x$ . Find by means of the trigonometric fundamental equation another two formulæ for  $\cos 2x$ .

A. Trigonometric formulæ.

D. Follow the description of the text and put  $y = x$ .

I. Since

$$\begin{aligned} \sin(x + y) &= \sin x \cdot \cos y + \cos x \cdot \sin y, \\ \sin(x - y) &= \sin x \cdot \cos y - \cos x \cdot \sin y, \\ \cos(x + y) &= \cos x \cdot \cos y - \sin x \cdot \sin y, \\ \cos(x - y) &= \cos x \cdot \cos y + \sin x \cdot \sin y, \end{aligned}$$

we get for  $y = x$  in the first and third formula that

$$\sin 2x) \sin(x + x) = \sin x \cdot \cos x + \cos x \cdot \sin x = 2 \sin x \cdot \cos x,$$

and

$$\begin{aligned} \cos 2x &= \cos(x + x) = \cos x \cdot \cos x - \sin x \cdot \sin x \\ &= \cos^2 x - \sin^2 x \\ &= 2 \cos^2 x - 1 \\ &= 1 - 2 \sin^2 x. \end{aligned}$$

**Example 1.22** 1) Prove that

$$\ln x < x \quad \text{for every } x > 0,$$

by first proving that  $f(x) = x - \ln x$  is increasing for  $x > 1$ .

2) Apply (1) to prove that for every  $\alpha > 0$ ,

$$\ln x < \frac{1}{\alpha} x^\alpha, \quad x > 0.$$

3) Prove for every  $\beta > 0$  that

$$\frac{\ln x}{x^\beta} < \frac{\beta}{2} \cdot x^{-\beta/2}, \quad x > 0,$$

and conclude that

$$\frac{\ln x}{x^\beta} \rightarrow 0 \quad \text{for } x \rightarrow +\infty,$$

for every  $\beta > 0$ .

The logarithm therefore increases significantly slower than any power function of positive exponent.

**A.** Investigate the growth of the logarithm and of the power functions.

The procedure has been described in the text.

**D.** Follow this procedure.

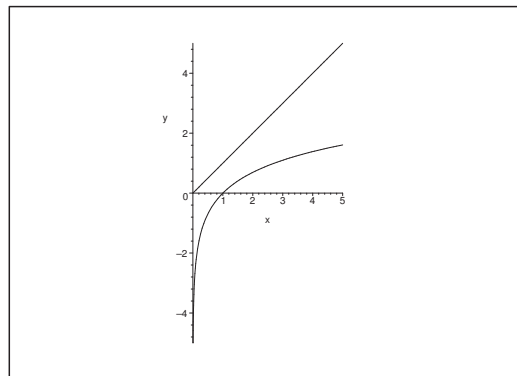

Figure 17: The graphs of  $y = x$  and  $y = \ln x$ ,  $x > 0$ .

**I.** 1) Let  $f : \mathbb{R}_+ \rightarrow \mathbb{R}$  be the differentiable function given by

$$f(x) = x - \ln x.$$

Then

$$f'(x) = 1 - \frac{1}{x},$$



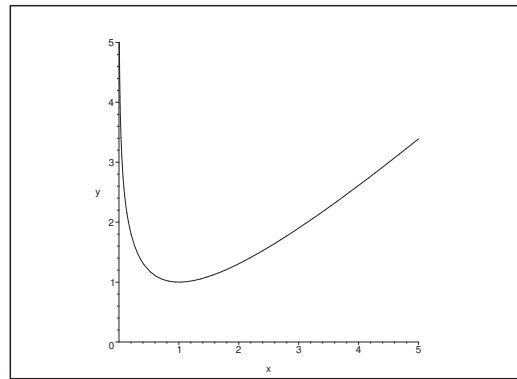

Figure 18: The graph of  $y = x - \ln x$ ,  $x > 0$ .

i.e.  $f$  is decreasing for  $x \in ]0, 1[$  and increasing for  $x \in ]1, +\infty[$ .  
 Hence,  $f$  has a global minimum for  $x = 1$ :

$$f(x) = x - \ln x \geq f(1) = 1 \quad \text{for every } x \in ]0, +\infty[.$$

Then by a rearrangement,

$$\ln x \leq x - 1 < x \quad \text{for alle } x \in ]0, +\infty[.$$

Please click the advert

**THE MILKWAY**  
**LAUNCHING GRADUATE CAREERS**

**MILKROUND SYSTEM**  
 Become a business star with internships, placements, graduate jobs & schemes from leading companies.  
[www.milkround.com](http://www.milkround.com)

**PLANET CAREER ADVICE**  
 Inhabited by insights into business careers and orbited by application advice.

**FIRST CONTACT**  
 Get matched to top business employers via intelligent emails landing in your inbox.

**Milkround.com: rated the #1 graduate recruitment website in the UK Graduate Careers Survey 2009 of 16,000 university finalists.**

**Milkround.com**

2) A replacement of  $x$  by  $x^\alpha$ ,  $x > 0$ ,  $\alpha > 0$  in the estimate above gives

$$\alpha \ln x = \ln(x^\alpha) < x^\alpha,$$

hence by a division by  $\alpha > 0$ ,

$$\ln x < \frac{1}{\alpha} x^\alpha, \quad x > 0, \quad \alpha > 0.$$

3) When we put  $\alpha = \frac{\beta}{2}$ ,  $\beta > 0$  in (2), we get

$$\ln x < \frac{2}{\beta} x^{\beta/2},$$

hence by insertion,

$$\frac{\ln x}{x^\beta} < \frac{2}{\beta} \frac{x^{\beta/2}}{x^\beta} = \frac{2}{\beta} \cdot x^{-\beta/2}, \quad x > 0.$$

Now  $\beta > 0$  and  $x^{\beta/2} \rightarrow +\infty$  for  $x \rightarrow +\infty$ , so we conclude that

$$\frac{\ln x}{x^\beta} \rightarrow 0 \quad \text{for } x \rightarrow +\infty$$

for every  $\beta > 0$ .

REMARK. Putting  $x = e^t$ ,  $t \in \mathbb{R}_+$ , we get from (3) that

$$\frac{\ln x}{x^\beta} = \frac{t}{e^{\beta t}} < \frac{2}{\beta} \exp\left(-\frac{\beta}{2} t\right) \rightarrow 0 \quad \text{for } t \rightarrow +\infty.$$

Thus, when  $\gamma > 0$ ,

$$\left(\frac{t}{e^{\beta t}}\right)^\gamma = \frac{t^\gamma}{e^{\beta\gamma t}} = \frac{t^\gamma}{a^t} \rightarrow 0 \quad \text{for } t \rightarrow +\infty$$

for every  $\gamma > 0$  and every  $a = e^{\beta\gamma} > 1$ .

The growth of any power function is therefore essentially slower than the growth of any exponential  $a^t$ ,  $a > 1$ , for  $t \rightarrow +\infty$ .

## 2 The hyperbolic functions

**Example 2.1** Apply the rule of differentiation of a fraction to derive

$$\frac{d(\coth x)}{dx} = -\frac{1}{\sinh^2 x} = 1 - \coth^2 x.$$

Then prove that

$$\coth x \rightarrow 1 \quad \text{for } x \rightarrow \infty \quad \text{and} \quad \coth x \rightarrow -1 \quad \text{for } x \rightarrow -\infty.$$

**A.** Investigation of the function  $f(x) = \coth x$ ,  $x \neq 0$ .

**D.** 1) Differentiate  $\coth x = \frac{\cosh x}{\sinh x}$ ,  $x \neq 0$ , as a fraction.

2) Check the limits by inserting the definitions of  $\cosh x$  and  $\sinh x$ .

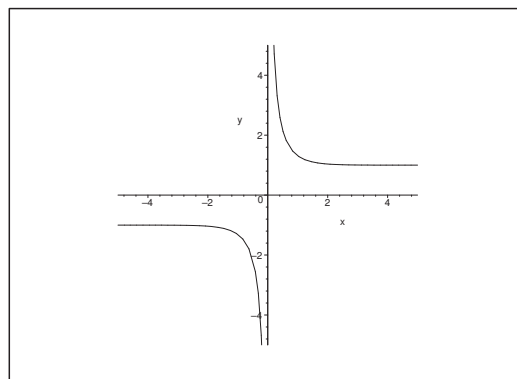

Figure 19: The graph of  $y = \coth x$ .

I. a) Using that  $f(x) = \frac{\cosh x}{\sinh x}$  we get for  $x \neq 0$ ,

$$\begin{aligned} f'(x) &= \frac{d}{dx} \left\{ \frac{\cosh x}{\sinh x} \right\} = \frac{\sinh x \cdot \sinh x - \cosh x \cdot \cosh x}{\sinh^2 x} \\ &= \frac{\sinh^2 x - \cosh^2 x}{\sinh^2 x} = -\frac{1}{\sinh^2 x} \\ &= 1 - \frac{\cosh^2 x}{\sinh^2 x} = 1 - \coth^2 x. \end{aligned}$$

b) From

$$\sinh x = \frac{1}{2}(e^x - e^{-x}) \quad \text{and} \quad \cosh x = \frac{1}{2}(e^x + e^{-x})$$

follows for  $x \neq 0$  that

$$\begin{aligned} \coth x &= \frac{e^x + e^{-x}}{e^x - e^{-x}} = 1 + \frac{2}{e^{2x} - 1} \\ &= \frac{1 + e^{-2x}}{1 - e^{-2x}} = -1 + \frac{2}{1 - e^{-2x}} = -1 - \frac{2}{e^{-2x} - 1}. \end{aligned}$$

When  $x \rightarrow +\infty$ , we get  $e^{2x} - 1 \rightarrow +\infty$ , and we obtain from the former expression that

$$\coth x = 1 + \frac{2}{e^{2x} - 1} \rightarrow 1 \quad \text{for } x \rightarrow +\infty.$$

When  $x \rightarrow +\infty$ , we get  $e^{-2x} - 1 \rightarrow +\infty$ , and we obtain from the latter expression that

$$\coth x = -1 - \frac{2}{e^{-2x} - 1} \rightarrow -1 \quad \text{for } x \rightarrow -\infty.$$

The claims are proved.

**Example 2.2** Prove directly the addition formulæ for  $\sinh(x \pm y)$ .

A. Prove the hyperbolic addition formulæ for  $\sinh$ .

D. Find e.g. the formulæ in a table and apply the definition of the functions involved.

I. We shall prove that

$$\sinh(x \pm y) = \sinh x \cdot \cosh y \pm \cosh x \cdot \sinh y,$$

Please click the advert



CHALLENGE  
YOURSELF

WWW.STUDYINSWEDEN.SE

Today's job market values ambitious, innovative, perceptive team players. Swedish universities foster these qualities through a forward-thinking culture where you're close to the latest ideas and global trends.

Whatever your career goals may be, studying in Sweden will give you valuable skills and a competitive advantage for your future. [www.studyinsweden.se](http://www.studyinsweden.se)

**Si.**  
Swedish Institute

Download free books at BookBooN.com

where

$$\cosh x = \frac{1}{2}(e^x + e^{-x}) \quad \text{and} \quad \sinh x = \frac{1}{2}(e^x - e^{-x}).$$

First note that it follows immediately from this that

$$\cosh y + \sinh y = e^y \quad \text{og} \quad \cosh y - \sinh y = e^{-y}.$$

Since  $\cosh(-y) = \cosh y$  og  $\sinh(-y) = -\sinh y$ , it is obvious that it suffices to prove that

$$\sinh(x + y) = \sinh x \cdot \cosh y + \cosh x \cdot \sinh y.$$

By inserting the definitions of  $\cosh x$  and  $\sinh x$  into the right hand side we get

$$\begin{aligned} & \sinh x \cdot \cosh y + \cosh x \cdot \sinh y \\ &= \frac{1}{2}(e^x - e^{-x}) \cosh y + \frac{1}{2}(e^x + e^{-x}) \sinh y \\ &= \frac{1}{2}e^x \{\cosh y + \sinh y\} - \frac{1}{2}e^{-x} \{\cosh y - \sinh y\} \\ &= \frac{1}{2}e^x e^y - \frac{1}{2}e^{-x} e^{-y} \\ &= \frac{1}{2} \{e^{x+y} - e^{-(x+y)}\} = \sinh(x + y), \end{aligned}$$

and we have proved the formula.

**Example 2.3** Sketch on the same figure the graphs of the functions  $y = \cosh x$  and  $y = 1 + x^2$ . Notice the difference of the form of the curves.

**A.** Sketch of curves.

**D.** Use e.g. MAPLE.

**I.** A possible MAPLE programme (among many others) is

```
plot({cosh(x), 1+x^2}, x=-4..4, y=-.2..cosh(4.1), color=black);
```

We see that the graph of  $\cosh x$  is “more flat” at the bottom and that it also increases faster towards  $\infty$ , when  $|x| \rightarrow \infty$ .

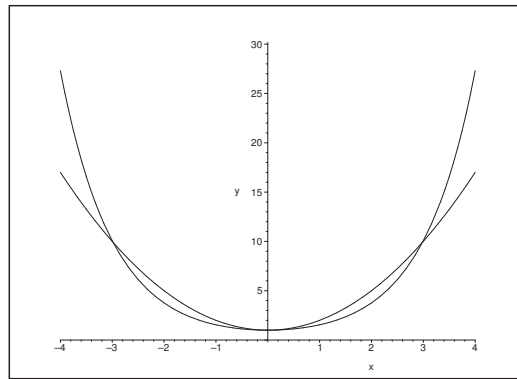
Figure 20: The graphs of  $\cosh x$  and  $1 + x^2$ .

**Example 2.4** Check in each of the following cases whether the formula is correct or wrong. If it is wrong, then correct the right hand side, such that the formula becomes correct.

- 1)  $\cosh 2x = 2 \cosh^2 x + 1$ ,  $x \in \mathbb{R}$ .
- 2)  $(\cosh x + \sinh x)^n = \cosh nx + \sinh nx$ ,  $x \in \mathbb{R}$ ,  $n \in \mathbb{N}$ .
- 3)  $\sinh 2x = \cosh^2 x + \sinh^2 x$ ,  $x \in \mathbb{R}$ .
- 4)  $\tanh \frac{x}{2} = \frac{\sinh x}{\cosh x - 1}$ ,  $x \neq 0$ .

**A.** Check some formulæ. Look in particular for obvious errors. We shall always assume that the left hand side is given.

**D.** Apply if possible the definitions.

- I.** 1) The first claim is clearly wrong. In fact, choose  $x = 0$ . Then  $\cosh 2x = 1$  and  $2 \cosh^2 x + 1 = 3 \neq 1$ .

In order to get the correct expression we apply the definition of  $\cosh$  on the left hand side. Then

$$\begin{aligned} \cosh 2x &= \frac{1}{2} \{e^{2x} + e^{-2x}\} = \frac{1}{2} \{e^{2x} + 2 + e^{-2x} - 2\} \\ &= 2 \left( \frac{e^x + e^{-x}}{2} \right)^2 - 1 = 2 \cosh^2 x - 1, \quad \text{for } x \in \mathbb{R}. \end{aligned}$$

- 2) This claim is correct. In fact,

$$\cosh x + \sinh x = \frac{1}{2} \{e^x + e^{-x}\} + \frac{1}{2} \{e^x - e^{-x}\} = e^x,$$

hence

$$(\cosh x + \sinh x)^n = (e^x)^n = e^{nx} = \cosh nx + \sinh nx, \quad x \in \mathbb{R}, \quad n \in \mathbb{N}.$$

- 3) This claim is wrong. The left hand side is an odd function, and the right hand side is even. The only function which is both odd and even is zero, so the two expressions do not agree. Apply the definition of sinh on the left hand side in order to get the correct formula,

$$\begin{aligned}\sinh 2x &= \frac{1}{2} \{e^{2x} - e^{-2x}\} = \frac{1}{2} \{e^x - e^{-x}\} \{e^x + e^{-x}\} \\ &= 2 \cdot \frac{e^x - e^{-x}}{2} \cdot e^x + e^{-x} 2 = 2 \sinh x \cdot \cosh x.\end{aligned}$$

- 4) This claim is wrong. We have for example  $\tanh 0 = 0$ , and it is easy to prove that

$$\left| \frac{\sinh x}{\cosh x - 1} \right| \rightarrow +\infty \quad \text{for } t \rightarrow 0.$$

This follows also when we below derive the correct formula:

$$\begin{aligned}\tanh \frac{x}{2} &= \frac{\sinh \frac{x}{2}}{\cosh \frac{x}{2}} = \frac{\exp\left(\frac{x}{2}\right) - \exp\left(-\frac{x}{2}\right)}{\exp\left(\frac{x}{2}\right) + \exp\left(-\frac{x}{2}\right)} \cdot \frac{\exp\left(\frac{x}{2}\right) + \exp\left(-\frac{x}{2}\right)}{\exp\left(\frac{x}{2}\right) + \exp\left(-\frac{x}{2}\right)} \\ &= \frac{e^x - e^{-x}}{e^x + e^{-x} + 2} = \frac{\frac{1}{2}(e^x - e^{-x})}{\frac{1}{2}(e^x + e^{-x}) + 1} \\ &= \frac{\sinh x}{\cosh x + 1}.\end{aligned}$$

Notice that the wrong formula only differ from the correct one by a sign in the denominator.

### 3 Inverse functions, general

**Example 3.1** Find the inverse function of the function

$$y = x^2 + 4x - 8, \quad x \geq -2.$$

What is the inverse function like when we change the domain to  $] - \infty, -2[$ ?

- A. Find the inverse function of a given function in some interval.  
 D. For given  $y$ , solve the equation with respect to  $x$ . Do not forget to indicate the corresponding  $y$ -interval (the domain of the inverse function).  
 I. From

$$y = x^2 + 4x - 8 = x^2 + 4x + 4 - 12 = (x + 2)^2 - 12,$$

follows that

$$(x + 2)^2 = y + 12 \geq 0,$$

from which we get the condition  $y \geq -12$ .

Please click the advert



## DIVERSE - INNOVATIVE - INTERNATIONAL

**Are you considering a European business degree?**

Copenhagen Business School is one of the largest business schools in Northern Europe with more than 15,000 students from Europe, North America, Australia and Asia.

Are you curious to know how a modern European business school competes with a diverse, innovative and international study environment?

Please visit Copenhagen Business School at [www.cbs.dk](http://www.cbs.dk)



**Copenhagen Business School**  
HANDELSHØJSKOLEN

Diversity creating knowledge



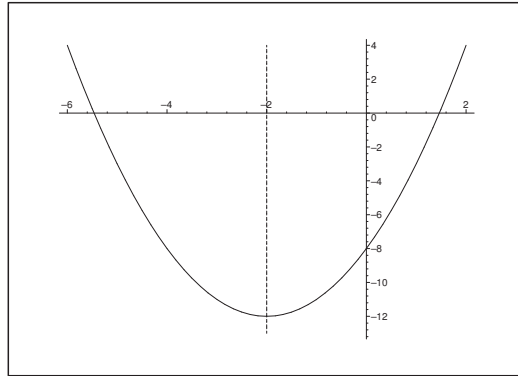

Figure 21: The graph of  $y = x^2 + 4x - 8$ .

The solution with respect to  $x$  becomes

$$x = -2 \pm \sqrt{y + 12}.$$

If  $x \geq -2$ , then the solution is

$$x = -2 + \sqrt{y + 12}, \quad y \in [-12, +\infty[.$$

If instead  $x < -2$ , then we shall change the sign,

$$x = -2 - \sqrt{y + 12}, \quad y \in ] - 12, +\infty[.$$

**Example 3.2** Indicate the inverse functions of the power functions  $y = x^\alpha$  and the exponential  $y = a^x$ .

**A.** Inverse functions.

**D.** Find the domain and the range and then the inverse function.

**I.** 1) Let  $y = x^\alpha$ ,  $x > 0$ ,  $y > 0$  and  $\alpha \in \mathbb{R}$ .

- a) If  $\alpha = 0$ , then we only get  $y = x^0 = 1$ , which is not strictly monotonous and the inverse function does not exist.
- b) If  $\alpha \neq 0$ , then  $y = x^\alpha$  is strictly monotonous (increasing for  $\alpha > 0$  and decreasing for  $\alpha < 0$ ), so the inverse function exists. We find this inverse function by raising the equation to the power  $\frac{1}{\alpha}$ ,

$$x = (x^\alpha)^{\frac{1}{\alpha}} = y^{\frac{1}{\alpha}}, \quad x > 0, \quad y > 0, \quad \alpha \in \mathbb{R} \setminus \{0\}.$$

2) Let  $y = a^x$ ,  $x \in \mathbb{R}$ ,  $y > 0$  and  $a > 0$ .

- a) If  $a = 1$ , we just get  $y = 1^x = 1$ , and the inverse function does not exist.

b) If instead  $a \in \mathbb{R}_+ \setminus \{1\}$ , we get by taking the logarithm,

$$\ln y = x \cdot \ln a.$$

Since  $\ln a \neq 0$  for  $a \in \mathbb{R}_+ \setminus \{1\}$ , the inverse function is

$$x = \frac{\ln y}{\ln a}, \quad x \in \mathbb{R}, \quad y > 0, \quad a \in \mathbb{R}_+ \setminus \{1\}.$$

**Example 3.3** *Argue why the function*

$$y = x^3 + x^2 + x + 1, \quad x \in \mathbb{R},$$

*has an inverse function  $x = \varphi(y)$ ,  $y \in \mathbb{R}$ . Find  $\varphi'(4)$ .*

**A.** Inverse function.

**D.** Prove that  $\psi(x) = x^3 + x^2 + x + 1$  is strictly increasing everywhere, i.e.  $\psi'(x) > 0$ .

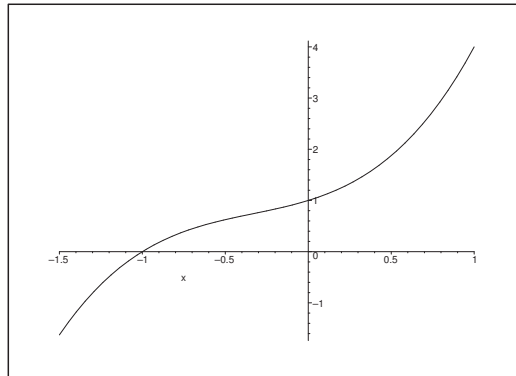

Figure 22: Part of the graph of  $y = x^3 + x^2 + x + 1$ .

**I.** The function  $\psi(x) = x^3 + x^2 + x + 1$ ,  $x \in \mathbb{R}$  is of class  $C^\infty$ , and

$$\psi'(x) = 3x^2 + 2x + 1 = 3 \left( x^2 + \frac{2}{3}x + \frac{1}{9} \right) + 1 - \frac{1}{3} = 3 \left( x + \frac{1}{3} \right)^2 + \frac{2}{3} > 0.$$

This shows that  $\psi(x)$  is strictly increasing for every  $x \in \mathbb{R}$ , hence the inverse function  $x = \varphi(y)$  exists.

We see by inspection that if  $x = 1$ , then  $y = \psi(1) = 4$ , and since the function  $\psi : \mathbb{R} \rightarrow \mathbb{R}$  maps  $\mathbb{R}$  bijectively onto itself, we conclude that  $y = 4$  also corresponds uniquely to  $x = 1$ . Since

$$y = \psi(x) = \psi(\varphi(y)),$$

we get by a differentiation with respect to  $y$  of the composite function that

$$1 = \psi'(x) \cdot \varphi'(y),$$

hence

$$\varphi'(4) = \frac{1}{\psi'(1)} = \frac{1}{3+2+1} = \frac{1}{6}.$$

**Example 3.4** Assume that  $y = f(x)$  and  $y = g(x)$  are two increasing and differentiable functions defined on  $\mathbb{R}$ . We denote their inverse functions by  $f^{-1}$  and  $g^{-1}$ , resp..

- 1) Write the formula for the derivative of the function  $y = F(x) = f(g(x))$ .
- 2) Write the formula for the derivative of the function  $x = f^{-1}(y)$ .
- 3) Write the formula for the inverse function  $x = F^{-1}(y)$  of the function in (1).
- 4) Write the formula for the derivative of the function  $x = F^{-1}(y)$ .

**A.** Formulæ for derivatives of inverse functions.

**D.** Apply the rule of differentiation of a composite function.

**I.** 1) This formula is well-known,

$$\frac{dy}{dx} = F'(x) = f'(g(x)) \cdot g'(x).$$

- 2) If  $x = f(f^{-1}(x))$ , we get by putting  $g(x) = f^{-1}(x)$  in (1) that

$$1 = \frac{dx}{dx} = f'(f^{-1}(x)) \cdot (f^{-1})'(x),$$

hence by a change of letters and a division,

$$(f^{-1})'(y) = \frac{1}{f'(f^{-1}(y))}.$$

REMARK. The corresponding heuristic calculation (which actually gives the right result, though the argument itself is mathematically wrong) is

$$\frac{dx}{dy} = \frac{1}{\frac{dy}{dx}} = \frac{1}{f'(x)} = \frac{1}{f'(f^{-1}(y))}. \quad \diamond$$

- 3) If  $y = F(x) = f(g(x))$ , then  $x = F^{-1}(y) = g^{-1}(f^{-1}(y))$ .

- 4) First we note that according to (1),

$$F'(x) = f'(g(x)) \cdot g'(x).$$

An insertion into the result of (2) gives

$$(F^{-1})'(y) = \frac{1}{F'(F^{-1}(y))} = \frac{1}{f'(g^{-1}(f^{-1}(y))) \cdot g'(g^{-1}(f^{-1}(y)))}.$$

## 4 The Arcus Functions

**Example 4.1** Find the derivative of  $y = \text{Arccos } x$ .

- A. The derivative of a given inverse function.
- D. Find e.g. the formula in a table. Then prove this formula.
- I. We get from every possible textbook on Calculus,

$$\frac{d(\text{Arccos } x)}{dx} = -\frac{1}{\sqrt{1-x^2}}, \quad \text{for } x \in ]-1, 1[.$$

We shall now prove this formula.

We know that  $y = \text{Arccos } x \in ]0, \pi[$  for  $x \in ]-1, 1[$ , and we see that it can be extended by continuity to the end points of the interval. The correspondence is given by  $x = f(y) = \cos y$ , where

$$f'(y) = -\sin y = -\sqrt{1-\cos^2 y} < 0 \quad \text{for } y \in ]0, \pi[,$$

because  $\sin y > 0$  for  $y \in ]0, \pi[$ .

Please click the advert



### Sharp Minds - Bright Ideas!

Employees at FOSS Analytical A/S are living proof of the company value - First - using new inventions to make dedicated solutions for our customers. With sharp minds and cross functional teamwork, we constantly strive to develop new unique products - Would you like to join our team?

FOSS works diligently with innovation and development as basis for its growth. It is reflected in the fact that more than 200 of the 1200 employees in FOSS work with Research & Development in Scandinavia and USA. Engineers at FOSS work in production, development and marketing, within a wide range of different fields, i.e. Chemistry, Electronics, Mechanics, Software, Optics, Microbiology, Chemometrics.

***We offer***  
*A challenging job in an international and innovative company that is leading in its field. You will get the opportunity to work with the most advanced technology together with highly skilled colleagues.*

*Read more about FOSS at [www.foss.dk](http://www.foss.dk) - or go directly to our student site [www.foss.dk/sharpminds](http://www.foss.dk/sharpminds) where you can learn more about your possibilities of working together with us on projects, your thesis etc.*

The Family owned FOSS group is the world leader as supplier of dedicated, high-tech analytical solutions which measure and control the quality and production of agricultural, food, pharmaceutical and chemical products. Main activities are initiated from Denmark, Sweden and USA with headquarters domiciled in Hillerød, DK. The products are marketed globally by 23 sales companies and an extensive net of distributors. In line with the corevalue to be 'First', the company intends to expand its market position.

Dedicated Analytical Solutions

FOSS  
 Slangerupgade 69  
 3400 Hillerød  
 Tel. +45 70103370  
[www.foss.dk](http://www.foss.dk)



Thus,

$$\begin{aligned}\frac{d(\operatorname{Arccos} x)}{dx} &= \left[ \frac{1}{f'(y)} \right]_{y=\operatorname{Arccos} x} \\ &= -\frac{1}{\sqrt{1-\cos^2(\operatorname{Arccos} x)}} = -\frac{1}{\sqrt{1-x^2}},\end{aligned}$$

for  $x \in ]-1, 1[$ .

**Example 4.2** 1) For which  $x \in \mathbb{R}$  is it true that

$$\operatorname{Arccos}(\cos x) = x?$$

2) For which  $x \in \mathbb{R}$  is it true that

$$\cos(\operatorname{Arccos} x) = x?$$

**A.** Find the domains of two formulæ.

**D.** Check the definition, the domain and the range for the given functions.

**I.** We know that  $\operatorname{Arccos}$  is defined by

$$y = \cos x \Leftrightarrow x = \operatorname{Arccos} y, \quad \text{when } x \in [0, \pi] \text{ and } y \in [-1, 1].$$

1) Let  $x \in [0, \pi]$ , and put  $y = \cos x \in [-1, 1]$ . Then

$$x = \operatorname{Arccos} y = \operatorname{Arccos}(\cos x), \quad x \in [0, \pi].$$

Since  $\operatorname{Arccos}(\cos x) \in [0, \pi]$ , we conclude that the formula is never right, when  $x \notin [0, \pi]$ . Hence, the formula is correct, if and only if  $x \in [0, \pi]$ .

2) The left hand side is only defined when  $x \in [-1, 1]$ . In this case we put  $y = \operatorname{Arccos} x \in [0, \pi]$ . When  $x$  and  $y$  are exchanged in the correspondence above, we get

$$x = \cos y = \cos(\operatorname{Arccos} x), \quad \text{for } x \in [-1, 1].$$

**Example 4.3** Check if the following claims are right or wrong.

1)  $y = \operatorname{Arcsin} x \Rightarrow \sin y = x.$

2)  $\cos y = \sqrt{1 - \sin^2 y}.$

3)  $\cos(\operatorname{Arcsin} x) = \sqrt{1 - x^2}.$

**A.** Investigation of functions. Check if some claims are correct or not.

**D.** Check the functions and their domains, ranges, etc..

I. 1) The claim is obviously true.

2) This claim is wrong, when  $y \in \left] \frac{\pi}{2} + 2p\pi, \frac{3\pi}{2} + 2p\pi \right[$ ,  $p \in \mathbb{Z}$ , because then the left hand side becomes negative, while the right hand side is always  $\geq 0$ .

On the other hand, the claim is correct, when  $y \in \left[ -\frac{\pi}{2} + 2p\pi, \frac{\pi}{2} + 2p\pi \right]$ ,  $p \in \mathbb{Z}$ .

3) Even if this is not obvious, the claim is true.

If  $x \in [-1, 1]$ , Then  $\text{Arcsin } x \in \left[ -\frac{\pi}{2}, \frac{\pi}{2} \right]$ . Since  $\cos y \geq 0$  in this interval, we get

$$\cos(\text{Arcsin } x) = +\sqrt{1 - \sin^2(\text{Arcsin } x)} = \sqrt{1 - x^2}.$$

**Example 4.4** Prove that

$$\text{Arcsin}(\cos x) = \frac{\pi}{2} - x, \quad x \in [0, \pi].$$

What is the corresponding formula for  $x \in [-\pi, 0]$ ?

A. Prove one given formula, and derive another one.

D. Since the functions are defined and continuously differentiable for  $x \in ]0, \pi[$ , it is sufficient to show that they have the same derivative everywhere, and that they agree in just one point.

Perform a similar analysis for  $x \in [-\pi, 0]$ .

Here we can produce an alternative solution.

I. 1) Both  $\text{Arcsin}(\cos x)$  and  $\frac{\pi}{2} - x$  are continuous for  $x \in [0, \pi]$ , and  $\sin x \geq 0$  in this interval. For  $x = \frac{\pi}{2}$  we get

$$\text{Arcsin}\left(\cos \frac{\pi}{2}\right) = \text{Arcsin } 0 = 0 = \frac{\pi}{2} - \frac{\pi}{2},$$

hence the functions agree at the point  $x = \frac{\pi}{2}$ .

Both functions are of class  $C^\infty$ , when  $x \in ]0, \pi[$ . and we see that

$$\begin{aligned} \frac{d}{dx} \text{Arcsin}(\cos x) &= \frac{1}{\sqrt{1 - \cos^2 x}} \cdot (-\sin x) = \frac{-\sin x}{+\sin x} \\ &= -1 = \frac{d}{dx} \left( \frac{\pi}{2} - x \right). \end{aligned}$$

By an integration we see that the two functions only differ from each other by a constant, and since we have shown above that the constant is 0, the formula follows by continuity at the end points.

2) If  $x \in ]-\pi, 0[$ , then  $\sin x < 0$ , hence

$$\frac{d}{dx} \operatorname{Arcsin}(\cos x) = \frac{-\sin x}{\sqrt{1-\cos^2}} = \frac{-\sin x}{|\sin x|} = \frac{-\sin x}{-\sin x} = 1.$$

By an integration we therefore get

$$\operatorname{Arcsin}(\cos x) = x + c \quad \text{for } x \in ]-\pi, 0[.$$

It follows from the continuity that this is also true at the end points.

When we put  $x = -\frac{\pi}{2}$ , we get

$$\operatorname{Arcsin}\left(\cos\left(-\frac{\pi}{2}\right)\right) = \operatorname{Arcsin} 0 = 0 = -\frac{\pi}{2} + c,$$

i.e.  $c = \frac{\pi}{2}$ , and we get the formula

$$\operatorname{Arcsin}(\cos x) = \frac{\pi}{2} + x, \quad \text{for } x \in [-\pi, 0].$$

All things considered we have proved that

$$\operatorname{Arcsin}(\cos x) = \frac{\pi}{2} - |x|, \quad \text{for } x \in [-\pi, \pi].$$

Please click the advert







[www.1calendar.dk](http://www.1calendar.dk)

AN ALTERNATIVE SOLUTION.

1) If  $x \in [0, \pi]$ , then  $\frac{\pi}{2} - x \in \left[-\frac{\pi}{2}, \frac{\pi}{2}\right]$ , i.e.

$$\text{Arcsin}\left(\sin\left(\frac{\pi}{2} - x\right)\right) = \frac{\pi}{2} - x, \quad \text{for } x \in [0, \pi].$$

From

$$\sin\left(\frac{\pi}{2} - x\right) = \sin\frac{\pi}{2} \cdot \cos(-x) + \cos\frac{\pi}{2} \cdot \sin(-x) = \cos x,$$

we get

$$\text{Arcsin}(\cos x) = \frac{\pi}{2} - x, \quad \text{for } x \in [0, \pi].$$

2) If  $x \in [-\pi, 0]$ , then  $-x \in [0, \pi]$ . Then we get by the first solution that

$$\text{Arcsin}(\cos(-x)) = \frac{\pi}{2} - (-x),$$

i.e.

$$\text{Arcsin}(\cos x) = \frac{\pi}{2} + x \quad \text{for } x \in [-\pi, 0].$$

3) As a conclusion we have

$$\text{Arcsin}(\cos x) = \frac{\pi}{2} - |x| \quad \text{for } x \in [-\pi, \pi].$$

**Example 4.5** Prove that

$$\cos(2 \text{Arcsin } x) = 1 - 2x^2, \quad x \in [-1, 1].$$

**A.** Prove a formula.

**D.** Apply the formula for  $\cos 2y$ .

**I.** It follows directly from  $\cos 2y = 1 - 2 \sin^2 y$  that

$$\cos(2 \text{Arcsin } x) = 1 - 2 \sin^2(\text{Arcsin } x) = 1 - 2x^2, \quad x \in [-1, 1].$$



**Example 4.6** Find the complete solution  $x = \varphi(t)$  of the differential equation

$$\frac{dx}{dt} = \frac{1+x^2}{1+t^2}.$$

*Hint: Use that*

$$\tan(u+v) = \frac{\tan u + \tan v}{1 - \tan u \cdot \tan v}.$$

**A.** A nonlinear differential equation of first order, where the variables can be separated.

**D.** Solve the differential equation by separating the variables.

**I.** Since both  $\frac{1}{1+x^2}$  and  $\frac{1}{1+t^2}$  are defined in the whole of  $\mathbb{R}$ , we get

$$\int \frac{1}{1+x^2} dx = \int \frac{1}{1+t^2} dt,$$

i.e.

$$\text{Arctan } x = \text{Arctan } t + k.$$

We shall now use the hint with  $c = \tan k$ ,

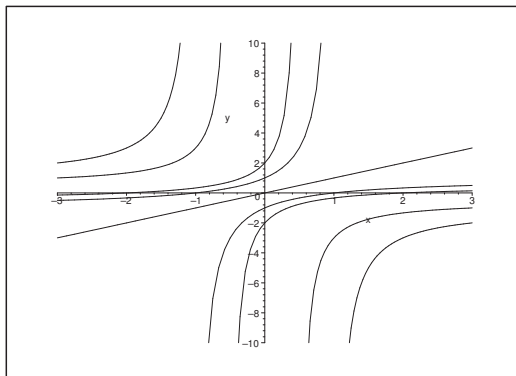

Figure 23: Some solution curves of  $\frac{dx}{dt} = \frac{1+x^2}{1+t^2}$ .

$$\begin{aligned} x &= \tan(\text{Arctan } x) = \tan(\text{Arctan } t + k) \\ &= \frac{t + \tan k}{1 - t \cdot \tan k} = \frac{t + c}{1 - ct}, \end{aligned}$$

which is defined for  $t \neq \frac{1}{c}$ ,  $c \neq 0$ . When  $c = 0$ , we of course get  $x = 0$ .

**Example 4.7** *Guess two solutions of the differential equation*

$$\frac{d^2x}{dt^2} + a^2x = 0.$$

*Then guess two solutions of the differential equation*

$$\frac{d^2x}{dt^2} = a^2x.$$

- A.** Solve linear and homogeneous differential equations of second order by qualified guessing.
- D.** Which functions are carried over into themselves, apart from a constant, when we differentiate twice?
- I.** It is well-known that

$$\frac{d^2}{dt^2} \cos at = -a^2 \cos at, \quad \frac{d^2}{dt^2} \sin at = -a^2 \sin at,$$

and that

$$\frac{d^2}{dt^2} \cosh at = a^2 \cosh at, \quad \frac{d^2}{dt^2} \sinh at = a^2 \sinh at.$$

This implies that  $x = \cos at$  and  $x = \sin at$  both satisfy the linear and homogeneous differential equation

$$\frac{d^2x}{dt^2} + a^2x = 0.$$

Since  $\cos at$  and  $\sin at$  are linearly independent, and the structure of the solution contains precisely two arbitrary constants, we conclude that the complete solution is given by

$$x = c_1 \cos at + c_2 \sin at, \quad t \in \mathbb{R}, \quad c_1, c_2 \in \mathbb{R} \text{ arbitrary constants.}$$

Similarly we see that  $x = \cosh at$  and  $x = \sinh at$  are both linearly independent solutions of the differential equation

$$\frac{d^2x}{dt^2} = a^2x,$$

hence this equation has the complete solution

$$x = c_1 \cosh at + c_2 \sinh at, \quad t \in \mathbb{R}, \quad c_1, c_2 \in \mathbb{R} \text{ arbitrary constants.}$$

**REMARK 1.** We have implicitly above assumed that  $a > 0$  (or just  $a \neq 0$ ). For completeness we mention that if  $a = 0$ , then the complete solution is

$$x = c_1 + c_2t,$$

which follows from two successive integrations of

$$\frac{d^2x}{dt^2} = 0. \quad \diamond$$

REMARK 2. Note that the equation  $\frac{d^2x}{dt^2} = a^2x$  is equivalent to

$$0 = \frac{d^2x}{dt^2} - a^2x = \left\{ \frac{d}{dt} - aI \right\} \circ \left\{ \frac{dx}{dt} + ax \right\},$$

where  $I$  denotes the identical operator  $Ix = x$ . This equation is solved by successively solving the system of two linear differential equations of first order

$$\frac{dz}{dt} - az = 0, \quad z = \frac{dx}{dt} + ax. \quad \diamond$$

Please click the advert

**Design your  
own future at  
MAN Diesel**

[www.mandiesel.com](http://www.mandiesel.com)

**MAN Diesel** – Powering the World



Download free books at [BookBooN.com](http://BookBooN.com)

**Example 4.8** First prove that if  $y = \text{Arctan } x$ , then

$$\frac{1 - \cos^2 y}{\cos^2 y} = x^2.$$

Then find an algebraic expression for  $\cos(\text{Arctan } x)$ ,  $x \in \mathbb{R}$ . (An algebraic expressions contains only power functions, root functions and the four basic operations of calculus.)

**A.** We shall reduce a formula to an algebraic expression. To that end there is given a hint.

**D.** The hint is proved by some simple geometry. Then apply this formula in order to find an algebraic expression for  $\cos(\text{Arctan } x)$ .

**I.** Let  $y = \text{Arctan } x \in \left] -\frac{\pi}{2}, \frac{\pi}{2} \right[$  for  $x \in \mathbb{R}$ . Then  $\cos y > 0$ , and

$$\frac{1 - \cos^2 y}{\cos^2 y} = \frac{\sin^2 y}{\cos^2 y} = \tan^2 y = \tan^2(\text{Arctan } x) = x^2,$$

and we have proved the formula.

It follows from this formula that

$$1 + x^2 = \frac{1}{\cos^2 y} = \frac{1}{\cos^2(\text{Arctan } x)}.$$

Since  $\cos y > 0$ , we get

$$\cos(\text{Arctan } x) = +\frac{1}{\sqrt{1+x^2}}, \quad x \in \mathbb{R}.$$

**Example 4.9** Find the exact values of the following:

$$(1) \text{Arccos } \frac{1}{2}; \quad (2) \text{Arctan} \left( \tan \frac{2\pi}{3} \right); \quad (3) \cos \left( \text{Arctan} \frac{3}{4} \right).$$

**A.** Calculate some exact values of expressions containing Arcus functions.

Analyze suitable figures and some known formulæ.

**I.** 1) Since  $\cos \frac{\pi}{3} = \frac{1}{2}$ , and  $\frac{\pi}{3} \in [0, \pi]$ , we conclude that

$$\text{Arccos } \frac{1}{2} = \frac{\pi}{3}.$$

2) Since  $\tan(x + \pi) = \tan x$  and  $\text{Arctan } y \in \left] -\frac{\pi}{2}, \frac{\pi}{2} \right[$ , we conclude that

$$\text{Arctan} \left( \tan \frac{2\pi}{3} \right) = \text{Arctan} \left( \tan \left( -\frac{\pi}{3} \right) \right) = -\frac{\pi}{3} \in \left] -\frac{\pi}{2}, \frac{\pi}{2} \right[.$$

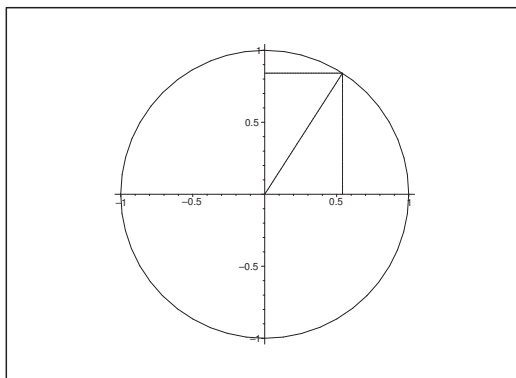

Figure 24: The unit circle with a vector, making the angle  $\theta$  with the  $x$ -axis. Then the projection onto the  $x$ -axis is  $\cos \theta$ , and the projection onto the  $y$ -axis is  $\sin \theta$ .

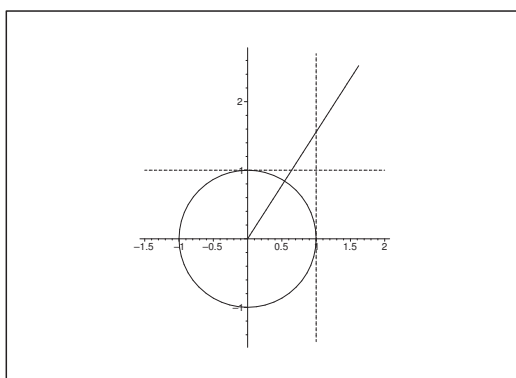

Figure 25: The unit circle with a tangent-axis (zero at  $(1, 0)$  on the  $x$ -axis and pointing upwards) and a cotangent-axis (zero at  $(0, 1)$  on the  $y$ -axis and pointing *towards the right*). When some line from  $(0, 0)$  form the angle  $\theta$  with the  $x$ -axis, we get  $\tan \theta$  on the tangent-axis, and  $\cot \theta$  on the cotangent-axis. If on the other hand  $c = \tan \theta$  is given, we draw this value on the tangent-axis and the line from  $(0, 0)$  to this point then forms the angle  $\theta$  with the  $x$ -axis. Similarly if  $c = \cot \theta$  is given.

3) Since  $\text{Arctan } x \in \left] -\frac{\pi}{2}, \frac{\pi}{2} \right[$ , we get  $\cos(\text{Arctan } x) > 0$ . Furthermore,

$$\cos y = \frac{+1}{\sqrt{1 + \tan^2 y}} \quad \text{for } \cos y > 0,$$

so

$$\cos \left( \text{Arctan } \frac{3}{4} \right) = \frac{+1}{\sqrt{1 + \tan^2 \left( \text{Arctan } \frac{3}{4} \right)}} = \frac{1}{\sqrt{1 + \left( \frac{3}{4} \right)^2}} = \frac{4}{5}.$$

**Example 4.10** Calculate the following integrals by means of partial integration:

$$(1) \int 1 \cdot \operatorname{Arcsin} x \, dx, \quad x \in [-1, 1]; \quad (2) \int \operatorname{Arctan} x \, dx, \quad x \in \mathbb{R}.$$

**A.** Integration problems.

**D.** Apply partial integration. In the first case we first consider  $x \in ]-1, 1[$ , and then extend afterwards by continuity.

**I.** 1) Let  $x \in ]-1, 1[$ . Then we get by partial integration,

$$\begin{aligned} \int 1 \cdot \operatorname{Arcsin} x \, dx &= x \cdot \operatorname{Arcsin} x - \int x \cdot \frac{1}{\sqrt{1-x^2}} \, dx \\ &= x \cdot \operatorname{Arcsin} x + \frac{1}{2} \int \frac{d(1-x^2)}{\sqrt{1-x^2}} \\ &= x \cdot \operatorname{Arcsin} x + \sqrt{1-x^2}. \end{aligned}$$

Since the result can be extended continuously to  $[-1, 1]$ , we conclude that this closed interval is the domain.

**C.** TEST: We get by a differentiation

$$\begin{aligned} \frac{d}{dx} \left\{ x \cdot \operatorname{Arcsin} x + \sqrt{1-x^2} \right\} &= \operatorname{Arcsin} x + \frac{x}{\sqrt{1-x^2}} - \frac{x}{\sqrt{1-x^2}} \\ &= \operatorname{Arcsin} x. \end{aligned}$$

Please click the advert

**Student Discounts**



+

**Student Events**



+

**Money Saving Advice**



=

**Happy Days!**





2) Similarly we get

$$\begin{aligned} \int 1 \cdot \operatorname{Arctan} x \, dx &= x \cdot \operatorname{Arctan} x - \int x \cdot \frac{1}{1+x^2} \, dx \\ &= x \cdot \operatorname{Arctan} x - \frac{1}{2} \ln(1+x^2). \end{aligned}$$

C. TEST. We get by a differentiation

$$\begin{aligned} \frac{d}{dx} \left\{ x \cdot \operatorname{Arctan} x - \frac{1}{2} \ln(1+x^2) \right\} \\ = \operatorname{Arctan} x + \frac{x}{1+x^2} - \frac{1}{2} \cdot \frac{2x}{1+x^2} = \operatorname{Arctan} x. \end{aligned}$$

**Example 4.11** Find the maximal domains of the functions

(1)  $f(x) = \operatorname{Arccos}(\cos x)$ ,      (2)  $\cos(\operatorname{Arccos} x)$ ,

and sketch their graphs.

A. Two functions.

D. Analyze them.

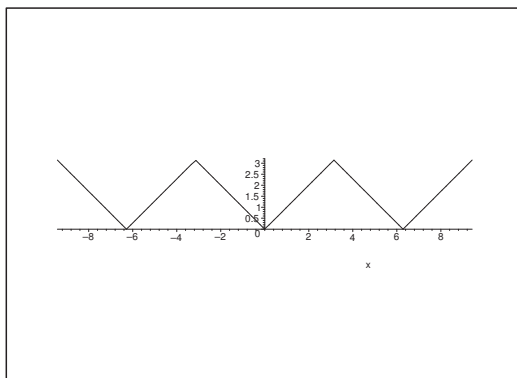

Figure 26: The graph of  $f(x) = \operatorname{Arccos}(\cos(x))$ .

I. 1) The function  $\operatorname{Arccos} y$  is defined for  $y \in [-1, 1]$ . Since  $y = \cos x \in [-1, 1]$  for every  $x \in \mathbb{R}$ , the domain of  $f$  is the whole of  $\mathbb{R}$ .

The range of  $\operatorname{Arccos} y$  is  $[0, \pi]$ . Since

$$\cos(-x) = \cos x \quad \text{and} \quad \cos(2p\pi + x) = \cos x, \quad p \in \mathbb{Z},$$

we get  $f(x) = |x|$  for  $x \in [-\pi, \pi]$ , continued periodically with the period  $2\pi$ .

2) The maximal domain of  $g(x)$  is  $[-1, 1]$ , and in this interval we have

$$\cos(\operatorname{Arccos} x) = x, \quad x \in [-1, 1].$$

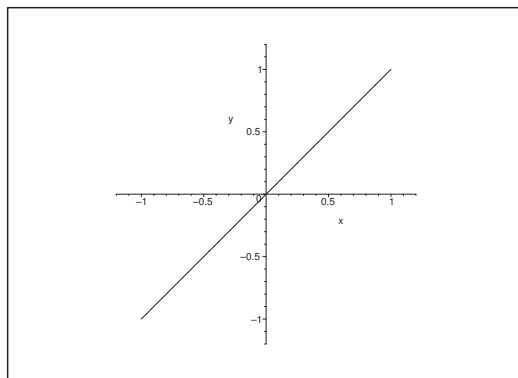
Figure 27: The graph of  $g(x) = \cos(\text{Arccos}(x))$ ,  $x \in [-1, 1]$ .

**Example 4.12** 1) Sketch the graph of the function

$$f(x) = \text{Arccot} \frac{1}{x}, \quad x \neq 0.$$

2) Show that the constants  $c_+$  and  $c_-$  can be fixed in such a way that

$$\text{Arccot} \frac{1}{x} = \begin{cases} \text{Arctan } x + c_- & \text{for } x < 0, \\ \text{Arctan } x + c_+ & \text{for } x > 0. \end{cases}$$

**A.** Analysis of a function.

**D.** Differentiate and start with the second question.

**I.** When  $x \neq 0$ , we get by a differentiation that

$$f'(x) = -\frac{1}{1 + \frac{1}{x^2}} \left( -\frac{1}{x^2} \right) = \frac{1}{1 + x^2} = \frac{d}{dx} \text{Arctan } x.$$

When we integrate again we conclude that

$$\text{Arccot} \frac{1}{x} = \begin{cases} \text{Arctan } x + c_- & \text{for } x < 0, \\ \text{Arctan } x + c_+ & \text{for } x > 0. \end{cases}$$

If  $x = 1$  we have  $\text{Arccot } 1 = \frac{\pi}{4} = \text{Arctan } 1 + c_+ = \frac{\pi}{4} + c_+$ , dvs.  $c_+ = 0$ .

For  $x = -1$  we have  $\text{Arccot}(-1) = \frac{3\pi}{4} = \text{Arctan}(-1) + c_- = \frac{\pi}{4} + c_-$ , dvs.  $c_- = \pi$ .

Finally we conclude that

$$\text{Arccot} \frac{1}{x} = \begin{cases} \text{Arctan } x + \pi, & \text{for } x < 0, \\ \text{Arctan } x, & \text{for } x > 0. \end{cases}$$



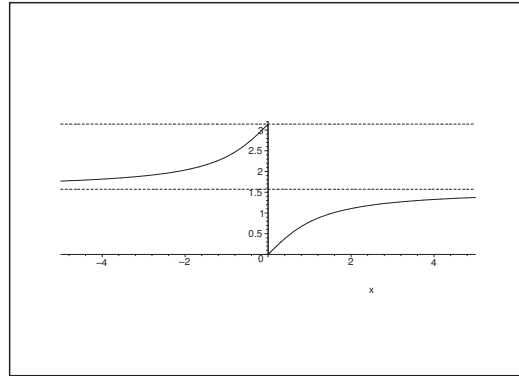

Figure 28: The graph of  $\text{Arccot} \frac{1}{x}$  for  $x \neq 0$ .

**Example 4.13** Calculate the integral  $\int \sqrt{1-x^2} dx$ .

**A.** Integration.

**D.** Substitute in a suitable way.

**I.** We must of course require that  $x \in [-1, 1]$ . If we put  $x = \cos t$ ,  $t \in [0, \pi]$ , we see that this substitution is monotonous decreasing and that  $dx = -\sin t dt$  and

$$\sqrt{1-x^2} = \sqrt{1-\cos^2 t} = \sqrt{\sin^2 t} = |\sin t| = \sin t \quad \text{for } t \in [0, \pi].$$

Hence by insertion and an application of the fact that  $t = \text{Arccos } x$ ,

$$\begin{aligned} \int \sqrt{1-x^2} dx &= \int \sin t \cdot (-\sin t) dt = -\int \sin^2 t dt \\ &= -\int \frac{1}{2}(1 - \cos 2t) dt = -\frac{1}{2}t + \frac{1}{4}\sin 2t \\ &= -\frac{1}{2}t + \frac{1}{2}\sin t \cdot \cos t = -\frac{1}{2}t + \frac{1}{2}\cos t \cdot \sqrt{1-\cos^2 t} \\ &= -\frac{1}{2}\text{Arccos } x + \frac{1}{2}x\sqrt{1-x^2} \\ &= \frac{1}{2}\text{Arcsin } x - \frac{\pi}{4} + \frac{1}{2}x\sqrt{1-x^2}, \end{aligned}$$

where the last result is either obtained from

$$\text{Arcsin } x + \text{Arccos } x = \frac{\pi}{2},$$

(the derivative is 0, and for  $x = 0$  we get the value  $\frac{\pi}{2}$ ), or by using the substitution  $x = \sin t$ ,  $t \in \left[-\frac{\pi}{2}, \frac{\pi}{2}\right]$ , instead with  $dx = \cos t dt$ . Apart from some obvious changes these calculations become quite similar.

**Example 4.14** 1) Prove the formula for the derivative of  $y = \text{Arctan } x$ .

2) Show that

$$\text{Arctan } x < x \quad \text{for all } x > 0.$$

*Hint: First prove that  $f(x) = x - \text{Arctan } x$  is an increasing function.*

3) Indicate the inequality between  $\text{Arctan } x$  and  $x$  for  $x < 0$ .

4) Show that

$$\tan x > x \quad \text{for } x \in \left]0, \frac{\pi}{2}\right[.$$

**A.** Analysis of the function  $y = \text{Arctan } x$ .

**D.** 1) Apply the theorem of differentiation of an inverse function.

2) Follow the guideline above.

3) Modify the method from (2).

4) Note that  $y = \text{Arctan } x$  is the inverse of  $x = \tan y$  and then use (2). It is also possible ALTERNATIVELY to prove the claim directly.

Please click the advert

## WHAT'S MISSING IN THIS EQUATION?

You could be one of our future talents

### MAERSK INTERNATIONAL TECHNOLOGY & SCIENCE PROGRAMME

Are you about to graduate as an **engineer** or **geoscientist**? Or have you already graduated?  
If so, there may be an exciting future for you with A.P. Moller - Maersk.



**MAERSK**

[www.maersk.com/mitas](http://www.maersk.com/mitas)

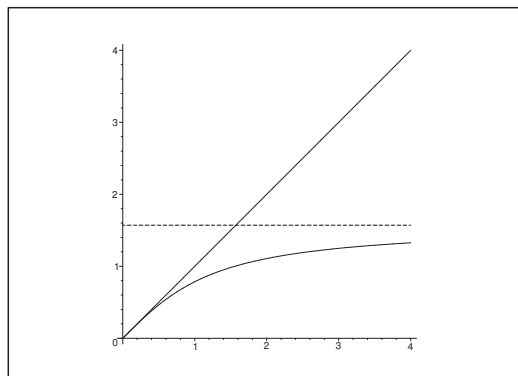

Figure 29: The graphs of  $y = x$  (above) and  $y = \text{Arctan } x$  (below), and the asymptote of the latter (dotted line).

I. 1) If  $x = f(y) = \tan y$ ,  $y \in \left] -\frac{\pi}{2}, \frac{\pi}{2} \right[$ , then

$$\frac{dx}{dy} = 1 + \tan^2 y > 0,$$

and we conclude that the inverse function exists,

$$y = g(x) = \text{Arctan } x, \quad x \in \mathbb{R}.$$

We get according to the theorem of differentiating an inverse function,

$$g'(x) = \frac{1}{f'(g(x))} = \frac{1}{1 + \tan^2(\text{Arctan } x)} = \frac{1}{1 + x^2}.$$

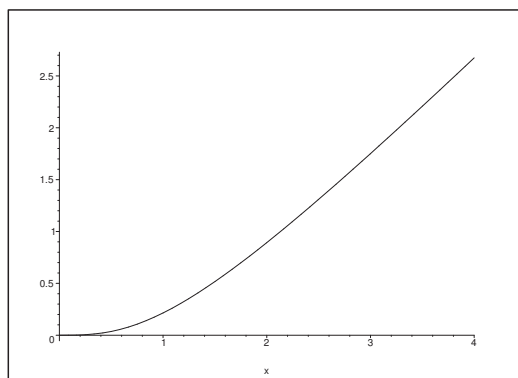

Figure 30: The graph of  $y = x - \text{Arctan } x$ ,  $x > 0$ .

2) Let  $f(x) = x - \text{Arctan } x$ ,  $x \in \mathbb{R}$ . Then, according to (1),

$$f'(x) = 1 - \frac{1}{1 + x^2} = \frac{x^2}{1 + x^2} > 0 \quad \text{for } x \neq 0.$$

Since  $f(0) = 0$ , we get

$$0 < f(x) = x - \operatorname{Arctan} x \quad \text{for } x > 0,$$

(and  $0 > f(x) = x - \operatorname{Arctan} x$  for  $x < 0$ ), hence by a rearrangement,

$$\operatorname{Arctan} x < x \quad \text{for } x > 0.$$

3) It follows from (2) that

$$0 > x - \operatorname{Arctan} x \quad \text{for } x < 0,$$

i.e.

$$\operatorname{Arctan} x > x \quad \text{for } x < 0.$$

4) Let  $y \in \left]0, \frac{\pi}{2}\right[$ . Then  $x = \tan y > 0$ , and  $\operatorname{Arctan} x = y$ . By insertion into the inequality in (2) we get

$$y < \tan y, \quad y \in \left]0, \frac{\pi}{2}\right[.$$

ALTERNATIVELY we put  $f(x) = \tan x - x$ . Then  $f(0) = 0$ , and

$$f'(x) = \tan^2 x > 0 \quad \text{for } x \in \left]0, \frac{\pi}{2}\right[,$$

thus

$$0 < \tan x - x, \quad x \in \left]0, \frac{\pi}{2}\right[,$$

and

$$\tan x > x, \quad x \in \left]0, \frac{\pi}{2}\right[.$$

**Example 4.15** Let the function  $f(x)$  be defined by

$$f(x) = \operatorname{Arcsin} \frac{2x}{1+x^2}.$$

- 1) Find the domain of the derivative of  $f(x)$ , and then  $f'(x)$  for  $x \neq \pm 1$ .
- 2) Find the relation between  $f(x)$  and the function

$$g(x) = \operatorname{Arctan} x.$$

- 3) Show that

$$\sin(2 \operatorname{Arctan} x) = \frac{2x}{1+x^2}, \quad x \in \mathbb{R}.$$

**A.** Analysis of a function and proof of some formulæ.

- D.** 1) Find the domain of the derivative and calculate  $f'(x)$ .
- 2) Compare with  $x$ .
  - 3) Derive a formula. Either by means of (2), or by proving that the two sides of the equation agree in one point and that they have the same derivative.

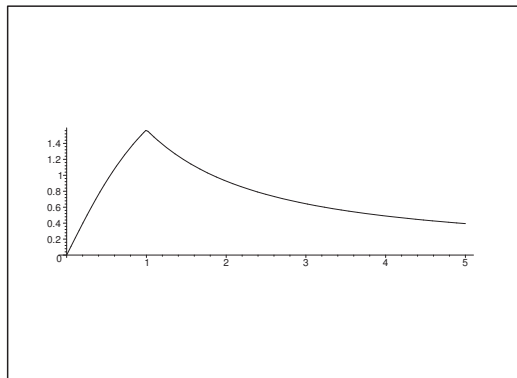

Figure 31: The graph of  $y = \operatorname{Arcsin} \left( \frac{2x}{1+x^2} \right)$ ,  $x > 0$ .

- I.** 1) The function  $\operatorname{Arcsin} y$  is only defined for  $y \in [-1, 1]$ . Therefore, we must require that

$$\left| \frac{2x}{1+x^2} \right| \leq 1,$$

an inequality which is rewritten as  $2|x| \leq 1+x^2$ , or as  $(|x|-1)^2 \geq 0$ . Now, this is always fulfilled, so  $f(x)$  is defined for every  $x \in \mathbb{R}$ .

Furthermore,  $f(x)$  is differentiable for  $\left| \frac{2x}{1+x^2} \right| < 1$ , i.e. for  $(|x| - 1)^2 > 0$ , or  $x \neq \pm 1$ . When this is the case we get by differentiation of the composite function that

$$\begin{aligned} f'(x) &= + \frac{1}{\sqrt{1 - \left(\frac{2x}{1+x^2}\right)^2}} \cdot \frac{2 \cdot (1+x^2) - 2x \cdot 2x}{(1+x^2)^2} \\ &= \frac{2}{\sqrt{(1+x^2)^2 - (2x)^2}} \cdot \frac{1-x^2}{1+x^2} \\ &= \frac{2}{\sqrt{(1+x^2+2x)(1+x^2-2x)}} \cdot \frac{1-x^2}{1+x^2} \\ &= \frac{2}{\sqrt{(1+x)^2(1-x)^2}} \cdot 1 - x^2 = 1 + x^2 \\ &= \frac{2}{|1-x^2|} \cdot \frac{1-x^2}{1+x^2} = \begin{cases} 2 \cdot \frac{1}{1+x^2}, & \text{for } |x| < 1, \\ -2 \cdot \frac{1}{1+x^2}, & \text{for } |x| > 1. \end{cases} \end{aligned}$$

Please click the advert

# CHALLENGE YOURSELF

[WWW.STUDYINSWEDEN.SE](http://WWW.STUDYINSWEDEN.SE)

Today's job market values ambitious, innovative, perceptive team players. Swedish universities foster these qualities through a forward-thinking culture where you're close to the latest ideas and global trends.

**Si.**  
Swedish Institute

Whatever your career goals may be, studying in Sweden will give you valuable skills and a competitive advantage for your future. [www.studyinsweden.se](http://www.studyinsweden.se)

2) Let  $g(x) = \text{Arctan } x$ . Then  $g'(x) = \frac{1}{1+x^2}$ , hence by the above,

$$f'(x) = \begin{cases} 2g'(x), & \text{for } |x| < 1, \\ -2g'(x), & \text{for } |x| > 1. \end{cases}$$

When we integrate this in each of the three domains  $] -\infty[$  and  $] -1, 1[$  and  $]1, +\infty[$ , we get

$$\begin{aligned} f(x) &= \text{Arcsin} \left( \frac{2x}{1+x^2} \right) = 2g(x) + c \\ &= 2 \text{Arctan } x + c, \quad |x| < 1; \\ f(x) &= \text{Arcsin} \left( \frac{2x}{1+x^2} \right) = c - 2g(x) \\ &= c - 2 \text{Arctan } x, \quad |x| > 1. \end{aligned}$$

Choosing  $x = 0 \in ] -1, 1[$ , we get  $c = 0$  in the first formula, i.e.

$$\text{Arcsin} \left( \frac{2x}{1+x^2} \right) = 2 \text{Arctan } x, \quad x \in ] -1, 1[.$$

When  $x \rightarrow +\infty$  in the last formula (i.e.  $x \in ]1, +\infty[$ ), we get

$$c = \text{Arcsin} \left( \frac{2x}{1+x^2} \right) + 2 \text{Arctan } x \rightarrow 0 + 2 \cdot \frac{\pi}{2} = \pi, \quad x \rightarrow +\infty.$$

Since  $c$  is constant through the limit, we must have  $c = \pi$ , so

$$\text{Arcsin} \left( \frac{2x}{1+x^2} \right) = \pi - 2 \text{Arctan } x, \quad x \in ]1, +\infty[.$$

Similarly, when  $x \rightarrow -\infty$  (i.e.  $x \in ] -\infty, -1[$ ),

$$c = \text{Arcsin} \left( \frac{2x}{1+x^2} \right) + 2 \text{Arctan } x \rightarrow 0 - 2 \cdot \frac{\pi}{2} = -\pi, \quad x \rightarrow -\infty,$$

i.e.  $c = -\pi$  for  $x \in ] -\infty, -1[$ , and

$$\text{Arcsin} \left( \frac{2x}{1+x^2} \right) = -\pi - 2 \text{Arctan } x, \quad x \in ] -\infty, -1[.$$

All things put together we see that

$$\text{Arcsin} \left( \frac{2x}{1+x^2} \right) = \begin{cases} \pi - 2 \text{Arctan } x, & x \in ]1, +\infty[, \\ 2 \text{Arctan } x, & x \in ] -1, 1[, \\ -\pi - 2 \text{Arctan } x, & x \in ] -\infty, -1[. \end{cases}$$

Now,  $f(x)$  is continuous for every  $x \in \mathbb{R}$ , and all the right hand sides are continuous in each their domains. Then the formulæ must by continuity also be valid at the end points. Then by a rearrangement,

$$(2) \quad 2g(x) = 2 \text{Arctan } x = \begin{cases} \pi - \text{Arcsin} \left( \frac{2x}{1+x^2} \right), & x \in [1, +\infty[, \\ \text{Arcsin} \left( \frac{2x}{1+x^2} \right), & x \in [-1, 1], \\ -\pi - \text{Arcsin} \left( \frac{2x}{1+x^2} \right), & x \in ] -\infty, -1]. \end{cases}$$

3) Apply sinus on (2),

$$\begin{aligned} \sin(2 \operatorname{Arctan} x) &= \sin\left(\pi - \operatorname{Arcsin}\left(\frac{2x}{1+x^2}\right)\right) \\ &= \sin\left(\operatorname{Arcsin}\left(\frac{2x}{1+x^2}\right)\right) = \frac{2x}{1+x^2}, & x \in [1, +\infty[, \\ \sin(2 \operatorname{Arctan} x) &= \sin\left(\operatorname{Arcsin}\left(\frac{2x}{1+x^2}\right)\right) = \frac{2x}{1+x^2}, & x \in [-1, 1], \\ \sin(2 \operatorname{Arctan} x) &= \sin\left(-\pi - \operatorname{Arcsin}\left(\frac{2x}{1+x^2}\right)\right) \\ &= \sin\left(\pi - \operatorname{Arcsin}\left(\frac{2x}{1+x^2}\right)\right) \\ &= \sin\left(\operatorname{Arcsin}\left(\frac{2x}{1+x^2}\right)\right) = \frac{2x}{1+x^2}, & x \in [1, +\infty[. \end{aligned}$$

We have proved that

$$\sin(2 \operatorname{Arctan} x) = \frac{2x}{1+x^2} \quad \text{for } x \in \mathbb{R}.$$

ALTERNATIVELY put  $u = \operatorname{Arctan} x$ ,  $x \in \mathbb{R}$ . Then

$$\begin{aligned} \sin(2 \operatorname{Arctan} x) &= \sin 2u = 2 \sin u \cdot \cos u \\ &= 2 \tan u \cdot \cos^2 u = \frac{2 \tan u}{1 + \tan^2 u} \\ &= \frac{2 \tan(\operatorname{Arctan} x)}{1 + \tan^2(\operatorname{Arctan} x)} = \frac{2x}{1+x^2}, & x \in \mathbb{R}. \end{aligned}$$

ALTERNATIVELY both

$$\varphi(x) = \sin(2 \operatorname{Arctan} x) \quad \text{and} \quad \psi(x) = \frac{2x}{1+x^2}$$

are differentiable in  $\mathbb{R}$ , and

$$\begin{aligned} \varphi'(x) &= \cos(2 \operatorname{Arctan} x) \cdot \frac{2}{1+x^2} \\ &= \frac{\cos^2(\operatorname{Arctan} x) - \sin^2(\operatorname{Arctan} x)}{\cos^2(\operatorname{Arctan} x) + \sin^2(\operatorname{Arctan} x)} \cdot \frac{2}{1+x^2} \\ &= \frac{1 - \tan^2(\operatorname{Arctan} x)}{1 + \tan^2(\operatorname{Arctan} x)} \cdot \frac{2}{1+x^2} \\ &= \frac{1-x^2}{1+x^2} \cdot \frac{2}{1+x^2} = 2 \cdot \frac{1-x^2}{(1+x^2)^2}, \end{aligned}$$

and

$$\psi'(x) = \frac{2 \cdot (1+x^2) - 2x \cdot 2x}{(1+x^2)^2} = 2 \cdot \frac{1-x^2}{(1+x^2)^2} = \varphi'(x).$$

Then by an integration,  $c = \varphi(x) - \psi(x)$ , where  $c$  is given by

$$c = \varphi(0) - \psi(0) = \sin 0 - 0 = 0,$$



i.e.

$$\varphi(x) = \sin(2 \operatorname{Arctan} x) = \psi(x) = \frac{2x}{1+x^2}, \quad x \in \mathbb{R}.$$

**Example 4.16** Let the function  $f(x)$  be given by

$$f(x) = \operatorname{Arctan} \frac{1}{x} - \operatorname{Arccot} x, \quad x \neq 0.$$

- 1) Prove that  $f'(x) = 0$  for every  $x \neq 0$ .
- 2) Show that  $f(x)$  is not constant in its domain. Explain why this does not contradict the fact that if a differentiable function has the derivative zero in an interval, then the function is constant in the interval.
- 3) Find for every  $x \neq 0$  a simple expression for the function

$$g(x) = \operatorname{Arctan} \frac{1}{x} + \operatorname{Arctan} x.$$

**A.** Derivation of some formulæ.

**D.** 1) Show that the derivative is  $x \neq 0$ .

2) Check the domain once more.

3) Find a simple expression for a similar function.

**I.** 1) Obviously,  $f(x)$  is defined and differentiable for  $x \neq 0$ . When we differentiate for  $x \neq 0$  we get

$$f'(x) = \frac{1}{1 + \left(\frac{1}{x}\right)^2} \cdot \left(-\frac{1}{x^2}\right) - \frac{-1}{1+x^2} = -\frac{1}{1+x^2} + \frac{1}{1+x^2} = 0.$$

2) The domain  $\mathbb{R}_- \cup \mathbb{R}_+$  is not an interval. For  $x = 1$  we get

$$f(1) = \operatorname{Arctan} 1 - \operatorname{Arccot} 1 = \frac{\pi}{4} - \frac{\pi}{4} = 0.$$

For  $x = -1$  we get

$$f(-1) = \operatorname{Arctan}(-1) - \operatorname{Arccot}(-1) = -\frac{\pi}{4} - \frac{3\pi}{4} = -\pi.$$

Thus we conclude that

$$f(x) = \operatorname{Arctan} \frac{1}{x} - \operatorname{Arccot} x = \begin{cases} 0, & \text{for } x > 0, \\ -\pi, & \text{for } x < 0. \end{cases}$$

This is not a contradiction, because the union  $\mathbb{R}_- \cup \mathbb{R}_+$  is not an interval.

3) Let  $x \neq 0$ . Then by a differentiation,

$$g'(x) = \frac{1}{1 + \left(\frac{1}{x}\right)^2} \cdot \left(-\frac{1}{x^2}\right) + \frac{1}{1 + x^2} = 0,$$

so  $g(x)$  is constant for  $x < 0$  and  $x > 0$ , respectively. We find the constants by

$$g(-1) = \operatorname{Arctan}(-1) + \operatorname{Arctan}(-1) = -\frac{\pi}{2};$$

$$g(1) = \operatorname{Arctan} 1 + \operatorname{Arctan} 1 = \frac{\pi}{2},$$

hence

$$g(x) = \operatorname{Arctan} \frac{1}{x} + \operatorname{Arctan} x = \begin{cases} \frac{\pi}{2}, & \text{for } x > 0, \\ -\frac{\pi}{2}, & \text{for } x < 0. \end{cases}$$

Please click the advert

The advertisement features a collage of four images. The top-left image shows a person sitting at a desk with multiple computer monitors, working in an office. The top-right image shows two women in business attire; one is wearing a pink shirt and the other a white turtleneck, both smiling and engaged in conversation. The bottom-left image shows a man in a dark suit holding a white document or folder, standing in an office. The bottom-right image shows a modern, multi-story building with many windows illuminated at night. The entire advertisement is set against a dark blue background with a light blue wavy graphic element at the bottom.

[www.job.oticon.dk](http://www.job.oticon.dk)

**oticon**  
PEOPLE FIRST

Download free books at [BookBooN.com](http://BookBooN.com)

**Example 4.17** *Hydrogen peroxide,  $\text{H}_2\text{O}_2$ , is an unstable chemical connection, which decomposes according to the reaction equation*

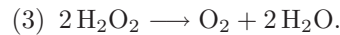

1. *The equation (3) implies that the concentration  $x$  of  $\text{H}_2\text{O}_2$  in a given solution satisfies the differential equation*

$$\frac{dx}{dt} = -kx^2, \quad x > 0, \quad t \geq 0.$$

*Find the concentration  $x$  in a solution where  $x(0) = c_0$  and  $c_0 > 0$ .*

*We then add a constant stream of a sulfite solution to the original solution, where the sulfite and the hydrogen peroxide immediately react according to the equation*

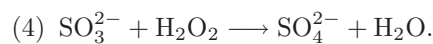

*If we add  $V$  mol  $\text{SO}_3^{2-}$  per second, then  $x(t)$  satisfies the differential equation*

$$\frac{dx}{dt} = -V - kx^2, \quad x \geq 0, \quad t \geq 0.$$

2. *Find  $x(t)$ , when  $x(0) = c_0$ , where  $c_0 > 0$ .*  
 3. *Find the time  $T$  (expressed by  $V$ ,  $k$  and  $c_0$ ), when all  $\text{H}_2\text{O}_2$  in the solution has been spent, and show that  $T \rightarrow +\infty$  for  $V \rightarrow +\infty$  for  $V \rightarrow 0+$ , where  $k$  and  $c_0$  are fixed constants.*

**A.** *Mathematical models. The real task is to solve two differential equations. In both cases the variables can be separated.*

- D.** 1) *Solve the equation by the method of separation.*  
 2) *Discuss the reasonableness of the equation, and then solve it.*  
 3) *Find  $T$  from the solution of (2), where  $x(T) = 0$ . Show that*

$$\lim_{v \rightarrow 0+} T = +\infty.$$

- I.** 1) *When we divide the equation by  $-x^2 \neq 0$  we get*

$$-\frac{1}{x^2} \frac{dx}{dt} = \frac{d}{dt} \left( \frac{1}{x} \right) = k,$$

*hence by an integration,*

$$\frac{1}{x} = kt + c.$$

*If  $t = 0$ , then  $x = c_0$ , so  $c = \frac{1}{c_0}$ , and the solution is given by*

$$x(t) = \frac{1}{kt + \frac{1}{c_0}} = \frac{c_0}{c_0kt + 1}, \quad x > 0, \quad t \geq 0.$$

- 2) When we add  $V > 0$  mol  $\text{SO}_3^{2-}$  per second, we also remove  $V$  mol  $\text{H}_2\text{O}_2$  per second, so  $\frac{dx}{dt}$  is furthermore diminished by  $V$ . This argument gives us the equation

$$\frac{dx}{dt} = -V - kx^2 = -V \left\{ 1 + \frac{k}{V} x^2 \right\}, \quad V > 0, \quad kV > 0.$$

By a separation of the variables we get

$$-\int V dt = c_1 - Vt = \int \frac{1}{1 + \frac{k}{V} x^2} dx = \sqrt{\frac{V}{k}} \cdot \text{Arctan} \left( \sqrt{\frac{k}{V}} \cdot x \right).$$

When  $t = 0$  we get  $x = c_0 > 0$ , hence

$$c_1 = \sqrt{\frac{V}{k}} \cdot \text{Arctan} \left( \sqrt{\frac{k}{V}} \cdot c_0 \right).$$

Now,  $x \geq 0$  is given, so the solution is therefore given implicitly by

$$\begin{aligned} \text{Arctan} \left( \sqrt{\frac{k}{V}} \cdot x \right) &= \sqrt{\frac{k}{V}} \{c_1 - Vt\} \\ &= \text{Arctan} \left( \sqrt{\frac{k}{V}} \cdot c_0 \right) - \sqrt{kV} \cdot t \in \left[ 0, \frac{\pi}{2} \right]. \end{aligned}$$

Since  $t \geq 0$  and  $\text{Arctan } y < \frac{\pi}{2}$ , we conclude that  $t$  must satisfy the inequalities

$$0 \leq t \leq \frac{1}{\sqrt{kV}} \text{Arctan} \left( \sqrt{\frac{k}{V}} \cdot c_0 \right),$$

and  $t$  lies in a bounded time interval.

Let  $c = \sqrt{kV}$ . Then  $V = \frac{c^2}{k}$  and  $\sqrt{\frac{k}{V}} = \frac{c}{V}$ , so we can write the equation in the form

$$\text{Arctan} \left( \frac{c}{V} \cdot x \right) = \text{Arctan} \left( \frac{c}{V} \cdot c_0 \right) - ct, \quad \text{where } t \in \left[ 0, \frac{1}{c} \text{Arctan} \left( \frac{c}{V} \cdot c_0 \right) \right].$$

In particular,  $t \neq \frac{\pi}{2c}$  in this interval. Apply tangent on this equation. Then

$$\begin{aligned} \frac{c}{V} \cdot c &= \tan \left\{ \text{Arctan} \left( \frac{c}{V} \cdot c_0 \right) - ct \right\} \\ &= \frac{\tan \left\{ \text{Arctan} \left( \frac{c}{V} \cdot c_0 \right) \right\} - \tan(ct)}{1 + \tan \left\{ \text{Arctan} \left( \frac{c}{V} \cdot c_0 \right) \right\} \cdot \tan(ct)} \\ &= \frac{\frac{c}{V} \cdot c_0 - \tan(ct)}{1 + \frac{c}{V} \cdot c_0 \cdot \tan(ct)}, \end{aligned}$$

from which

$$\begin{aligned} x &= \frac{V}{c} \cdot \frac{V}{c \cdot c_0} \cdot \frac{c}{\frac{1}{c_0} \cdot \frac{V}{c} - \tan(ct)} \\ &= \frac{V}{kc_0} \cdot \frac{c_0 \sqrt{\frac{k}{V}} - \tan(\sqrt{kV} \cdot t)}{\frac{1}{c_0} \sqrt{\frac{V}{k}} + \tan(\sqrt{kV} \cdot t)}, \\ &\quad \text{for } t \in \left[0, \frac{1}{\sqrt{kV}} \operatorname{Arctan} \left( \sqrt{\frac{k}{V}} \cdot c_0 \right) \right]. \end{aligned}$$

REMARK. I have checked this result, but I shall leave out the test, because it consists of calculations which are even worse than the calculations above.  $\diamond$

- 3) Since  $x(T) = 0$  is obtained by putting the numerator equal to 0 (apply the continuity), we must have

$$T = \frac{1}{\sqrt{kV}} \cdot \operatorname{Arctan} \left( c_0 \sqrt{\frac{k}{V}} \right).$$

When  $k > 0$  and  $c_0 > 0$  are kept fixed and  $V \rightarrow 0+$ , we get  $\frac{1}{\sqrt{kV}} \rightarrow +\infty$  and  $\operatorname{Arctan} \left( c_0 \sqrt{\frac{k}{V}} \right) \rightarrow \frac{\pi}{2}$ , så  $T \rightarrow +\infty$  for  $V \rightarrow 0+$ .

**Example 4.18** Prove that

$$\operatorname{Arctan} \left( \frac{1}{2} \left( x - \frac{1}{x} \right) \right) = \begin{cases} 2 \operatorname{Arctan} x - \frac{\pi}{2} & \text{for } x > 0, \\ 2 \operatorname{Arctan} x + \frac{\pi}{2} & \text{for } x < 0. \end{cases}$$

**A.** Here we shall see that the solution method is far from unique. I shall give a lot of variants.

The task is to prove a formula for an inverse function.

**D.** ANALYSIS. The left hand side is not defined for  $x = 0$ . The standard method is now to show that the two expressions for  $x \neq 0$  have the same derivative, thus they agree apart from a constant. Then by checking the values in some point  $x < 0$  and another one  $x > 0$  we show that the constant is 0 in both cases.

ALTERNATIVELY one may start by analyzing the function  $\psi(x) = \frac{1}{2} \left( x - \frac{1}{x} \right)$ ,  $x \neq 0$ , and then apply tan on both sides. Here we get some additional variants.

**I. First variant.** The standard method. The function

$$\varphi(x) = \operatorname{Arctan} \left( \frac{1}{2} \left\{ x - \frac{1}{x} \right\} \right)$$

is defined and infinitely often differentiable for  $x \neq 0$ . When  $x \neq 0$ , we get by a differentiation,

$$\begin{aligned}\varphi'(x) &= \frac{1}{1 + \left(\frac{1}{2}\left\{x - \frac{1}{x}\right\}\right)^2} \cdot \frac{1}{2} \left(1 + \frac{1}{x^2}\right) \\ &= \frac{4}{4 + \left(x - \frac{1}{x}\right)^2} \cdot \frac{1}{2} \cdot \frac{1+x^2}{x^2} = \frac{2}{x^2 + 2 + \frac{1}{x^2}} \cdot \frac{1+x^2}{x^2} \\ &= \frac{2(1+x^2)}{x^4 + 2x^2 + 1} = \frac{2(1+x^2)}{(x^2 + 1)^2} = \frac{2}{1+x^2}.\end{aligned}$$

An integration in each of the intervals  $] -\infty, 0[$  and  $]0, +\infty[$  gives

$$\varphi(x) = \operatorname{Arctan} \left( \frac{1}{2} \left\{ x - \frac{1}{x} \right\} \right) = \int 2x^2 + 1 \, dx + c = 2 \operatorname{Arctan} x + c.$$

Please click the advert

**CHALLENGE  
YOURSELF**

**WWW.STUDYINSWEDEN.SE**

**Si.**  
Swedish Institute

Today's job market values ambitious, innovative, perceptive team players. Swedish universities foster these qualities through a forward-thinking culture where you're close to the latest ideas and global trends.

Whatever your career goals may be, studying in Sweden will give you valuable skills and a competitive advantage for your future. [www.studyinsweden.se](http://www.studyinsweden.se)

Download free books at BookBooN.com

1) As a representative for  $x < 0$  we choose  $x = -1$ . Then

$$\begin{aligned}\varphi(-1) &= \operatorname{Arctan} \left( \frac{1}{2} \left\{ -1 - \frac{1}{-1} \right\} \right) = \operatorname{Arctan} 0 = 0 \\ &= 2 \operatorname{Arctan}(-1) + c_- = 2 \cdot \left( -\frac{\pi}{4} \right) + c_- = c_- - \frac{\pi}{2},\end{aligned}$$

hence  $c_- - \frac{\pi}{2} = 0$ , or  $c_- = \frac{\pi}{2}$ .

2) As a representative for  $x > 0$  we choose  $x = 1$ . Then

$$\begin{aligned}\varphi(1) &= \operatorname{Arctan} \left( \frac{1}{2} \left\{ 1 - \frac{1}{1} \right\} \right) = \operatorname{Arctan} 0 = 0 \\ &= 2 \operatorname{Arctan} 1 + c_+ = 2 \cdot \frac{\pi}{4} + c_+ = c_+ + \frac{\pi}{2},\end{aligned}$$

thus  $c_+ + \frac{\pi}{2} = 0$ , or  $c_+ = -\frac{\pi}{2}$ .

As a conclusion we obtain the wanted formulæ,

$$\operatorname{Arctan} \left( \frac{1}{2} \left\{ x - \frac{1}{x} \right\} \right) = \begin{cases} 2 \operatorname{Arctan} x - \frac{\pi}{2} & \text{for } x > 0, \\ 2 \operatorname{Arctan} x + \frac{\pi}{2} & \text{for } x < 0, . \end{cases}$$

**Second variant.** The function  $\psi(x) = \frac{1}{2} \left( x - \frac{1}{x} \right)$  has the derivative

$$\psi'(x) = \frac{1}{2} \left( 1 + \frac{1}{x^2} \right) = \frac{1+x^2}{2x^2} > 0 \quad \text{for } x \neq 0,$$

so  $\psi(x)$  is strictly increasing in each of the two subintervals  $] -\infty, 0[$  and  $] 0, +\infty[$ .

Then notice that

1) if  $x \rightarrow -\infty$ , then  $\psi(x) \rightarrow -\infty$ , and if  $x \rightarrow 0-$ , then  $\psi(x) \rightarrow +\infty$ ,

2) if  $x \rightarrow 0+$ , then  $\psi(x) \rightarrow -\infty$ , and if  $x \rightarrow +\infty$ , then  $\psi(x) \rightarrow +\infty$ .

We conclude that the range of  $\operatorname{Arctan} \left( \frac{1}{2} \left\{ x - \frac{1}{x} \right\} \right)$  is  $] -\frac{\pi}{2}, \frac{\pi}{2}[$  for both  $x \in ] -\infty, 0[$  and  $x \in ] 0, +\infty[$ .

1) If  $x > 0$ , then  $2 \operatorname{Arctan} x - \frac{\pi}{2} \in ] -\frac{\pi}{2}, \frac{\pi}{2}[$ , so the ranges are equal, and everything takes place in the interval  $] -\frac{\pi}{2}, \frac{\pi}{2}[$ . Thus it suffices to prove that

$$\tan \left( \operatorname{Arctan} \left( \frac{1}{2} \left\{ x - \frac{1}{x} \right\} \right) \right) = \tan \left( 2 \operatorname{Arctan} x - \frac{\pi}{2} \right), \quad \text{for } x > 0.$$

Here the left hand side is clearly equal to  $\frac{1}{2} \left( x - \frac{1}{x} \right)$ .

Let us turn to the right hand side. Put  $u = \operatorname{Arctan} x \in ] 0, \frac{\pi}{2}[$ , i.e.  $\tan u = x > 0$ . Then

we get by the addition formulæ,

$$\begin{aligned}\tan\left(2\operatorname{Arctan}x - \frac{\pi}{2}\right) &= \tan\left(2u - \frac{\pi}{2}\right) = \frac{\sin\left(2u - \frac{\pi}{2}\right)}{\cos\left(2u - \frac{\pi}{2}\right)} \\ &= \frac{-\cos(2u)}{+\sin(2u)} = -\frac{\cos^2 u - \sin^2 u}{2 \cos u \cdot \sin u} = \frac{1}{2} \frac{\sin^2 u - \cos^2 u}{\cos u \cdot \sin u} \\ &= \frac{1}{2} \cdot \frac{\tan^2 u - 1}{\tan u} = \frac{1}{2} \cdot \frac{x^2 - 1}{x} = \frac{1}{2} \left(x - \frac{1}{x}\right) \\ &= \tan\left(\operatorname{Arctan}\left(\frac{1}{2}\left\{x - \frac{1}{x}\right\}\right)\right),\end{aligned}$$

and the claim is proved for  $x > 0$ .

2) Then consider  $x < 0$ .

**First subvariant.** Since  $y = -x > 0$ , the formula holds for  $y$  according to (1), so

$$\operatorname{Arctan}\left(\frac{1}{2}\left\{y - \frac{1}{y}\right\}\right) = 2\operatorname{Arctan}y - \frac{\pi}{2}, \quad y > 0.$$

When we substitute back,  $y = -x$ , and use that  $\operatorname{Arctan}$  is an odd function, we get

$$-\operatorname{Arctan}\left(\frac{1}{2}\left\{x - \frac{1}{x}\right\}\right) = -2\operatorname{Arctan}x - \frac{\pi}{2}, \quad x < 0,$$

hence by a change of sign,

$$\operatorname{Arctan}\left(\frac{1}{2}\left\{x - \frac{1}{x}\right\}\right) = 2\operatorname{Arctan}x + \frac{\pi}{2}, \quad x < 0,$$

and we have proved the formula.

**Second subvariant.** When  $x < 0$ , we have  $2\operatorname{Arctan}x \in ]-\pi, 0[$ , so

$$2\operatorname{Arctan}x + \frac{\pi}{2} \in \left]-\frac{\pi}{2}, \frac{\pi}{2}\right[,$$

and everything takes place in the right interval. Thus it suffices to prove that

$$\tan\left(\operatorname{Arctan}\left(\frac{1}{2}\left\{x - \frac{1}{x}\right\}\right)\right) = \tan\left(2\operatorname{Arctan}x + \frac{\pi}{2}\right) \quad \text{for } x < 0.$$

Here the left hand side is clearly equal to  $\frac{1}{2}\left\{x - \frac{1}{x}\right\}$ .

Let us turn to the right hand side. Put  $u = \operatorname{Arctan}x \in \left]-\frac{\pi}{2}, 0\right[$ , i.e.

$\tan u = x < 0$ . Then by the addition formulæ

$$\begin{aligned}\tan\left(2\operatorname{Arctan}x + \frac{\pi}{2}\right) &= \tan\left(2u + \frac{\pi}{2}\right) = \frac{\sin\left(2u + \frac{\pi}{2}\right)}{\cos\left(2u + \frac{\pi}{2}\right)} \\ &= \frac{+\cos 2u}{-\sin 2u} = -\frac{\cos^2 u - \sin^2 u}{2 \cos u \cdot \sin u} = \frac{1}{2} \cdot \frac{\tan^2 u - 1}{\tan u} \\ &= \frac{1}{2} \cdot \frac{x^2 - 1}{x} = \frac{1}{2} \left(x - \frac{1}{x}\right) \\ &= \tan\left(\operatorname{Arctan}\left(\frac{1}{2}\left\{x - \frac{1}{x}\right\}\right)\right),\end{aligned}$$



and we have proved the claim for  $x < 0$ .

**Example 4.19** Find the derivative of the function

$$f(x) = \operatorname{Arctan} \sqrt{x^2 - 1} - \operatorname{Arccos} \frac{1}{x}, \quad x > 1,$$

and show that

$$\operatorname{Arctan} \sqrt{x^2 - 1} = \operatorname{Arccos} \frac{1}{x}, \quad x \geq 1.$$

**A.** Identity involving inverse trigonometric functions.

**D.** Just follow the sketch above.

It is obvious that  $f(x)$  is defined and continuous for  $x \geq 1$ . Then for  $x > 1$ , where  $f(x)$  is differentiable,

$$\begin{aligned} f'(x) &= \frac{1}{1 + (\sqrt{x^2 - 1})^2} \cdot \frac{x}{\sqrt{x^2 - 1}} - \left\{ -\frac{1}{\sqrt{1 - \frac{1}{x^2}}} \cdot \left(-\frac{1}{x^2}\right) \right\} \\ &= \frac{1}{1 + x^2 - 1} \cdot \frac{x}{\sqrt{x^2 - 1}} - \frac{1}{\frac{1}{x} \sqrt{x^2 - 1}} \cdot \frac{1}{x^2} \\ &= \frac{1}{x \sqrt{x^2 - 1}} - \frac{1}{x \sqrt{x^2 - 1}} = 0, \end{aligned}$$

which shows that  $f(x) = c$  is a constant for  $x > 1$ .

Since  $f(x)$  is continuous for  $x \geq 1$ , we also have

$$c = f(1) = \lim_{x \rightarrow 1^+} f(x) = \operatorname{Arctan}(\sqrt{1^2 - 1}) - \operatorname{Arccos}\left(\frac{1}{1}\right) = 0 - 0 = 0,$$

hence

$$f(x) = \operatorname{Arctan}(\sqrt{x^2 - 1}) - \operatorname{Arccos} \frac{1}{x} = 0 \quad \text{for } x \geq 1.$$

Finally we get by a rearrangement,

$$\operatorname{Arctan}(\sqrt{x^2 - 1}) = \operatorname{Arccos} \frac{1}{x} \quad \text{for } x \geq 1.$$

**Example 4.20** *Prove that*

$$\operatorname{Arcsin} x = \operatorname{Arctan} \frac{x}{\sqrt{1-x^2}}, \quad x \in ]-1, 1[.$$

- A.** An inverse trigonometric formula.
- D.** Show that the two functions have the same domain and the same derivative, and that they are equal in one point, proving that the constant must be 0.
- I.** Obviously, the two functions are defined for  $x \in ]-1, 1[$ . Furthermore,

$$\frac{d}{dx} \operatorname{Arcsin} x = \frac{1}{\sqrt{1-x^2}},$$

Please click the advert

## Turning a challenge into a learning curve. Just another day at the office for a high performer.

### Accenture Boot Camp – your toughest test yet

Choose Accenture for a career where the variety of opportunities and challenges allows you to make a difference every day. A place where you can develop your potential and grow professionally, working alongside talented colleagues. The only place where you can learn from our unrivalled experience, while helping our global clients achieve high performance. If this is your idea of a typical working day, then Accenture is the place to be.

It all starts at Boot Camp. It's 48 hours that will stimulate your mind and enhance your career prospects. You'll spend time with other students, top Accenture Consultants and special guests. An inspirational two days

packed with intellectual challenges and activities designed to let you discover what it really means to be a high performer in business. We can't tell you everything about Boot Camp, but expect a fast-paced, exhilarating

and intense learning experience. It could be your toughest test yet, which is exactly what will make it your biggest opportunity.

Find out more and apply online.

**Visit [accenture.com/bootcamp](https://www.accenture.com/bootcamp)**

• Consulting • Technology • Outsourcing

**accenture**  
*High performance. Delivered.*

and

$$\begin{aligned} \frac{d}{dx} \operatorname{Arctan} \frac{x}{\sqrt{1-x^2}} &= \frac{1}{1 + \frac{x^2}{1-x^2}} \cdot \left\{ \frac{1}{\sqrt{1-x^2}} + x \cdot \left(-\frac{1}{2}\right) \cdot \frac{-2x}{(\sqrt{1-x^2})^3} \right\} \\ &= \frac{1-x^2}{1-x^2+x^2} \cdot \left\{ \frac{1}{\sqrt{1-x^2}} + \frac{x^2}{(1-x^2) \cdot \sqrt{1-x^2}} \right\} \\ &= \frac{1}{\sqrt{1-x^2}} \cdot \{1-x^2+x^2\} = \frac{1}{\sqrt{1-x^2}} \\ &= \frac{d}{dx} \operatorname{Arcsin} x, \end{aligned}$$

so the two functions only differ from each other by a constant. Since both sides of the equation are 0 for  $x = 0$ , the constant is 0, and the two functions are equal,

$$\operatorname{Arcsin} x = \operatorname{Arctan} \frac{x}{\sqrt{1-x^2}}, \quad x \in ]-1, 1[.$$

**Example 4.21** Prove that for every  $x \in \mathbb{R}$ ,

$$\operatorname{Arctan}(\sinh(x)) = 2 \operatorname{Arctan}(e^x) - \frac{\pi}{2}.$$

- A. A mixed trigonometric and hyperbolic relation.
- D. The two sides of the equation are defined and continuously differentiable for every  $x \in \mathbb{R}$ . show that they agree in one single point and that they have the same derivative.

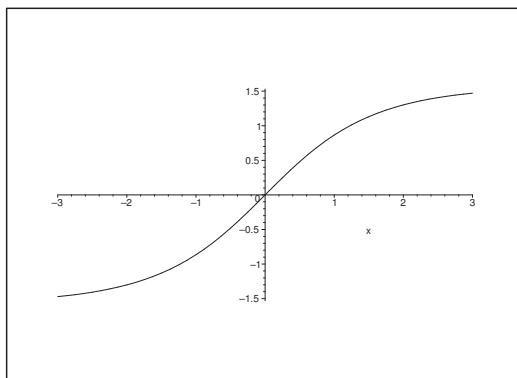

Figure 32: The graph of  $\operatorname{Arctan}(\sinh x)$ .

I. Since

$$\frac{d}{dx} \operatorname{Arctan}(\sinh x) = \frac{\cosh x}{1 + \sinh^2 x} = \frac{\cosh x}{\cosh^2 x} = \frac{1}{\cosh x}$$

and

$$\frac{d}{dx} \left\{ 2 \operatorname{Arctan}(e^x) - \frac{\pi}{2} \right\} = \frac{2e^x}{1+e^{2x}} = \frac{1}{\frac{e^x + e^{-x}}{2}} = \frac{1}{\cosh x},$$

the two functions have the same derivative, i.e. they can only differ by a constant.

From

$$\operatorname{Arctan}(\sinh 0) = \operatorname{Arctan} 0 = 0,$$

and

$$2 \operatorname{Arctan}(e^0) - \frac{\pi}{2} = 2 \operatorname{Arctan} 1 - \frac{\pi}{2} = \frac{\pi}{2} - \frac{\pi}{2} = 0,$$

we conclude that the difference is 0, so the two functions are equal,

$$\operatorname{Arctan}(\sinh x) = 2 \operatorname{Arctan}(e^x) - \frac{\pi}{2}.$$

**Example 4.22** 1) Prove that  $\sinh\left(\ln \frac{1}{3}\right) = -\frac{4}{3}$ , and find an exact expression for  $\cosh\left(\ln \frac{1}{3}\right)$ .

2) Find the complete solution of the differential equation

$$\frac{dx}{dt} - 2x \tanh(t) = (\cosh(t))^2 + (\cosh(t))^3, \quad t \in \mathbb{R}.$$

3) Find the particular solution  $x = \varphi(t)$ ,  $t \in \mathbb{R}$ , for which

$$\varphi\left(\ln \frac{1}{3}\right) = -\frac{100}{27}.$$

**A.** In reality the task is to solve a linear differential equation of first order with variable coefficients.

**D.** Apply some known formulæ. Check whether the questions are interfering.

**I.** 1) By the definition

$$\begin{aligned} \sinh\left(\ln \frac{1}{3}\right) &= \frac{1}{2} \left\{ \exp\left(\ln \frac{1}{3}\right) - \exp(\ln 3) \right\} \\ &= \frac{1}{2} \left\{ \frac{1}{3} - 3 \right\} = \frac{1}{2} \left( -\frac{8}{3} \right) = -\frac{4}{3}. \end{aligned}$$

Similarly,

$$\begin{aligned} \cosh\left(\ln \frac{1}{3}\right) &= \frac{1}{2} \left\{ \exp\left(\ln \frac{1}{3}\right) + \exp(\ln 3) \right\} \\ &= \frac{1}{2} \left( \frac{1}{3} + 3 \right) = \frac{1}{2} \cdot \frac{10}{3} = \frac{5}{3}. \end{aligned}$$

ALTERNATIVELY,

$$\cosh^2\left(\ln\frac{1}{3}\right) = 1 + \sinh^2\left(\ln\frac{1}{3}\right) = 1 + \frac{16}{9} = \frac{25}{9},$$

and since  $\cosh x > 0$  for every  $x \in \mathbb{R}$ , we get

$$\cosh\left(\ln\frac{1}{3}\right) = \frac{5}{3}.$$

2) Since

$$\int 2 \tanh t \, dt = \int 2 \cdot \frac{\sinh t}{\cosh t} \, dt = 2 \ln \cosh t = \ln \cosh^2 t,$$

it follows that  $\cosh^2 t$  is a solution of the corresponding homogeneous equation. Then a particular solution is given by

$$\cosh^2 t \int \{1 + \cosh t\} \, dt = (t + \sinh t) \cdot \cosh^2 t.$$

The complete solution is

$$\varphi(t) = (t + \sinh t) \cosh^2 t + c \cdot \cosh^2 t, \quad t \in \mathbb{R}, \quad c \in \mathbb{R}.$$

3) Finally.

$$\begin{aligned} -\frac{100}{27} &= \varphi\left(\ln\frac{1}{3}\right) \\ &= \cosh^2\left(\ln\frac{1}{3}\right) \cdot \left\{\ln\frac{1}{3} + \sinh\left(\ln\frac{1}{3}\right) + c\right\} \\ &= \left(\frac{5}{3}\right)^3 \cdot \left\{\ln\frac{1}{3} - \frac{4}{3} + c\right\}, \end{aligned}$$

hence

$$c = \frac{4}{3} - \ln\frac{1}{3} - \left(\frac{3}{5}\right)^2 \cdot \frac{100}{27} = \ln 3 + \frac{4}{3} - \frac{4}{3} = \ln 3.$$

The required particular solution is then

$$\varphi(t) = \{\ln 3 + t + \sinh t\} \cosh^2 t.$$

**Example 4.23** Prove that for every  $x > -1$  have

$$\operatorname{Arctan}\left(\frac{x-1}{x+1}\right) = \operatorname{Arctan}(x) - \frac{\pi}{4}.$$

**A.** A trigonometric relation.

**D.** Show that the two functions have the same derivative, so they can only differ by a constant. Then prove that the constant is 0.

**I.** When  $x > -1$ , we get by differentiating,

$$\begin{aligned} \frac{d}{dx} \operatorname{Arctan}\left(\frac{x-1}{x+1}\right) &= \frac{1}{1 + \left(\frac{x-1}{x+1}\right)^2} \cdot \frac{x+1 - (x-1)}{(x+1)^2} \\ &= \frac{2}{(x+1)^2 + (x-1)^2} = \frac{2}{2x^2 + 0 + 2} \\ &= \frac{1}{1+x^2} = \frac{d}{dx} \left\{ \operatorname{Arctan}(x) - \frac{\pi}{4} \right\}, \end{aligned}$$

and the two functions only differ by a constant.

If  $x = 1$ , we get

$$\operatorname{Arctan}\left(\frac{x-1}{x+1}\right) = \operatorname{Arctan} 0 = 0$$

and

$$\operatorname{Arctan} 1 - \frac{\pi}{4} = \frac{\pi}{4} - \frac{\pi}{4} = 0,$$

so the two functions are equal for  $x > -1$ , (and certainly not for  $x < -1$ ).

## 5 The Area functions

**Example 5.1** Find directly the inverse function of

$$y = \sinh x, \quad x \in \mathbb{R}.$$

- A.** Find the inverse function of a given monotonous function.
- D.** Apply the definition of  $\sinh x$  and solve the equation first with respect to  $e^x$  and then with respect to  $x$ .
- I.** The range of  $\sinh x$  is  $\mathbb{R}$ , so  $y \in \mathbb{R}$ . It follows from the definition of  $\sinh x$  that

$$y = \frac{1}{2} (e^x - e^{-x}),$$

hence

$$(e^x)^2 - 2y e^x - 1 = 0.$$

Please click the advert



it's an **interesting** world

### Get under the skin of it.

**Graduate opportunities**  
Cheltenham | £24,945 + benefits

One of the UK's intelligence services, GCHQ's role is two-fold: to gather and analyse intelligence which helps shape Britain's response to global events, and, to provide technical advice for the protection of Government communication and information systems. In doing so, our specialists – in IT, internet, engineering, languages, information assurance, mathematics and intelligence – get well beneath the surface of global affairs. If you thought the world was an interesting place, you really ought to explore our world of work.

[www.careersinbritishintelligence.co.uk](http://www.careersinbritishintelligence.co.uk)

Applicants must be British citizens. GCHQ values diversity and welcomes applicants from all sections of the community. We want our workforce to reflect the diversity of our work.



When we add  $y^2 + 1$  we get after a small rearrangement,

$$(e^x)^2 - 2y e^x + y^2 = (e^x - y)^2 = y^2 + 1.$$

Thus by taking the square root,

$$e^x = \left| y \pm \sqrt{y^2 + 1} \right|.$$

Since  $y < \sqrt{y^2 + 1}$  for every  $y$  we must have

$$e^x = y + \sqrt{y^2 + 1} > 0,$$

so by taking the logarithm we get the inverse function,

$$x = \ln \left( y + \sqrt{y^2 + 1} \right), \quad y \in \mathbb{R}.$$

**Example 5.2** Calculate the integral  $\int \sqrt{1 + x^2} dx$ .

**A.** An integral.

**D.** The trick is to find some monotonous function  $f(x)$ , such that it becomes easy to calculate the square root of  $1 + f(x)^2$ . Here we have at least two candidates,

$$(1) \quad x = \sinh t, \quad (2) \quad x = \tan t.$$

We shall treat both possibilities and learn that the calculations in the first variant are much easier to perform than the calculations in the second one.

**I. First variant.** Since  $1 + \sinh^2 t = \cosh^2 t$  and  $x = \sinh t$  is strictly increasing, we can choose this as a monotonous substitution. The “unpleasant thing” is that the inverse function

$$t = \operatorname{Arsinh} x = \ln \left( x + \sqrt{x^2 + 1} \right), \quad x \in \mathbb{R},$$

looks complicated. On the other hand,

$$\sqrt{1 + x^2} = \sqrt{1 + \sinh^2 t} = \cosh t \quad \text{and} \quad dx = \cosh t dt,$$

are quite simple, and since

$$\cosh 2t = \cosh^2 t + \sinh^2 t = 2 \cosh^2 t - 1,$$

i.e.

$$\cosh^2 t = \frac{1}{2} (1 + \cosh 2t),$$

we get the following calculation

$$\begin{aligned} \int \sqrt{1 + x^2} dx &= \int \cosh t \cdot \cosh t dt = \int \cosh^2 t dt \\ &= \frac{1}{2} (1 + \cosh 2t) dt = \frac{1}{2} t + \frac{1}{4} \sinh 2t \\ &= \frac{1}{2} \ln \left( x + \sqrt{x^2 + 1} \right) + \frac{1}{2} x \sqrt{x^2 + 1}. \end{aligned}$$



**Second variant.** ALTERNATIVELY (and it will soon be seen that this is somewhat more cumbersome) we know that

$$1 + \tan^2 t = \frac{1}{\cos^2 t}, \quad t \in \left] -\frac{\pi}{2}, \frac{\pi}{2} \right[ ,$$

which is of the desired structure. (The variant under consideration has been inspired by the fact that most students at this stage the trigonometric functions will be more familiar with them than with the hyperbolic functions, and it is well-known that one will always prefer to choose the known cases first.) Another possible monotonous substitution is therefore

$$x = \tan t, \quad \text{with the inverse function } t = \text{Arctan } x,$$

where

$$\sqrt{1+x^2} = \sqrt{1+\tan^2 t} = +\frac{1}{\cos t}, \quad dx = \frac{1}{\cos^2 t} dt.$$

Let us see what happens by insertion:

$$\begin{aligned} \int \sqrt{1+x^2} dx &= \int \frac{1}{\cos t} \cdot \frac{1}{\cos^2 t} dt = \int \frac{\cos t}{\cos^4 t} dt \\ &= \frac{d \sin t}{(1-\sin^2 t)^2} = \int_{u=\sin t} \frac{du}{(1-u^2)^2} \\ &= \int_{u=\sin t} \frac{du}{(1-u)^2(1+u)^2}. \end{aligned}$$

Here we shall first decompose the integrand. This is done by the method of “holding-your-hand-over-the-bad-terms”, cf. *Calculus 1a, Functions of One Variable*:

$$\begin{aligned} \frac{1}{(1-u)^2(1+u)^2} &= \frac{1}{4} \frac{1}{(1-u)^2} + \frac{1}{4} \frac{1}{(1+u)^2} + \frac{1}{4} \frac{4-(1+u)^2-(1-u)^2}{(1+u)^2(1+u)^2} \\ &= \frac{1}{4} \frac{1}{(1-u)^2} + \frac{1}{4} \frac{1}{(1+u)^2} + \frac{1}{4} \frac{4-2-2u^2}{(1-u)^2(1+u)^2} \\ &= \frac{1}{4} \frac{1}{(1-u)^2} + \frac{1}{4} \frac{1}{(1+u)^2} + \frac{1}{2} \frac{1}{(1-u)(1+u)} \\ &= \frac{1}{4} \frac{1}{(1-u)^2} + \frac{1}{2} \frac{1}{(1+u)^2} + \frac{1}{4} \frac{1}{1-u} + \frac{1}{4} \frac{1}{1+u}. \end{aligned}$$

Then by insertion,

$$\begin{aligned} \int \sqrt{1+x^2} dx &= \int \frac{du}{(1-u)^2(1+u)^2} \\ &= \frac{1}{4} \int \left\{ \frac{1}{(u-1)^2} + \frac{1}{(u+1)^2} - \frac{1}{u-1} + \frac{1}{u+1} \right\} du \\ &= \frac{1}{4} \left\{ -\frac{1}{u-1} - \frac{1}{u+1} - \ln |u-1| + \ln |u+1| \right\} \\ &= \frac{1}{4} \left\{ \frac{2u}{1-u^2} - \ln \left( \frac{1+u}{1-u} \right) \right\} \\ &= \frac{1}{4} \left\{ \frac{2 \sin t}{\cos^2 t} + \ln \left( \frac{1+\sin t}{1-\sin t} \right) \right\}. \end{aligned}$$

Since  $x = \tan t$ , we get

$$\cos t = \frac{1}{\sqrt{1+x^2}} \quad \text{and} \quad \sin t = \frac{x}{\sqrt{1+x^2}},$$

hence

$$\begin{aligned} \int \sqrt{1+x^2} dx &= \frac{1}{4} \left\{ \frac{2x}{\sqrt{1+x^2}} \cdot (1+x^2) + \ln \left( \frac{1 + \frac{x}{\sqrt{1+x^2}}}{1 - \frac{x}{\sqrt{1+x^2}}} \right) \right\} \\ &= \frac{1}{4} \left\{ 2x \sqrt{1+x^2} + \ln \left( \frac{\sqrt{1+x^2} + x}{\sqrt{1+x^2} - x} \cdot \frac{\sqrt{1+x^2} + x}{\sqrt{1+x^2} + x} \right) \right\} \\ &= \frac{1}{4} \left\{ 2x \sqrt{1+x^2} + \ln \left( (\sqrt{1+x^2} + x)^2 \right) \right\} \\ &= \frac{1}{2} x \sqrt{1+x^2} + \frac{1}{2} \ln (x + \sqrt{1+x^2}). \end{aligned}$$

**Example 5.3** 1) Find directly the inverse function  $x = \varphi(y)$  of

$$y = \tanh x, \quad x \in \mathbb{R}.$$

2) Find  $\varphi'(y)$ , either by directly to differentiate  $\varphi(y)$ , or by applying the theorem of differentiation of an inverse function.

**A.** Find the inverse  $\varphi(y)$  of  $y = \tanh x$ , and the derivative of  $\varphi(y)$ .

**D.** 1) Apply the definition of  $\tanh x$  and then solve with respect to  $x$ . Do not forget to specify the range of  $y$ .

2) Calculate  $\varphi'(y)$  in the two indicated ways.

**I.** 1) We first see that

$$\begin{aligned} y = \tanh x &= \frac{\sinh x}{\cosh x} = \frac{\frac{1}{2}(e^x - e^{-x})}{\frac{1}{2}(e^x + e^{-x})} \\ &= \frac{e^{2x} - 1}{e^{2x} + 1} = \frac{1 - e^{-2x}}{1 + e^{-2x}}. \end{aligned}$$

Since

$$-1 < -1 + \frac{2}{1 + e^{-x}} = \tanh x = 1 - \frac{1}{e^{2x} + 1} < 1,$$

where we can get as close to the two limits as we want, we conclude that  $y \in ]-1, 1[$ . In this case we get

$$y(e^{2x} + 1) = e^{2x} - 1, \quad y \in ]-1, 1[,$$

i.e.

$$e^{2x}(1-y) = y+1,$$

thus

$$e^{2x} = \frac{1+y}{1-y} > 0 \quad \text{for } y \in ]-1, 1[.$$

Hence the inverse function is

$$x = \varphi(y) = \frac{1}{2} \ln \left( \frac{1+y}{1-y} \right), \quad y \in ]-1, 1[.$$

2) When we differentiate

$$x = \varphi(y) = \frac{1}{2} \ln(1+y) - \frac{1}{2} \ln(1-y), \quad y \in ]-1, 1[,$$

we get

$$\begin{aligned} \frac{dx}{dy} &= \varphi'(y) = \frac{1}{2} \cdot \frac{1}{1+y} - \frac{1}{2} \cdot \frac{1}{1-y} \cdot (-1) \\ &= \frac{1}{2} \left\{ \frac{1}{1+y} + \frac{1}{1-y} \right\} = \frac{1}{1-y^2}, \quad y \in ]-1, 1[. \end{aligned}$$

Please click the advert



**Brain power**

By 2020, wind could provide one-tenth of our planet's electricity needs. Already today, SKF's innovative know-how is crucial to running a large proportion of the world's wind turbines.

Up to 25 % of the generating costs relate to maintenance. These can be reduced dramatically thanks to our systems for on-line condition monitoring and automatic lubrication. We help make it more economical to create cleaner, cheaper energy out of thin air.

By sharing our experience, expertise, and creativity, industries can boost performance beyond expectations. Therefore we need the best employees who can meet this challenge!

**The Power of Knowledge Engineering**

Plug into The Power of Knowledge Engineering.  
Visit us at [www.skf.com/knowledge](http://www.skf.com/knowledge)

**SKF**

Let  $f(x) = \tanh x$ . Then we get ALTERNATIVELY that  $f'(x) = 1 - \tanh^2 x > 0$ , and therefore by the theorem of differentiating an inverse function,

$$\varphi'(y) = \frac{1}{f'(\varphi(y))} = \frac{1}{1 - \tanh^2(\operatorname{Artanh} y)} = \frac{1}{1 - y^2}, \quad y \in ]-1, 1[.$$

**Example 5.4** A paratrooper of mass  $m$  jumps from the height  $h$ . We call the air resistance  $R$ , and we denote the gravitation by  $g$ . The paratrooper's vertical velocity is denoted by  $v(t)$ .

According to Newton's Second Law the equation for the paratrooper's vertical velocity is

$$(5) \quad m \frac{dv}{dt} = mg - R(v),$$

where  $R(v)$  is a function of  $v$ .

We assume that  $m = 90$  kg. It is empirically known that the paratrooper's velocity at the surface of the Earth (no matter the initial height) is approximately 7 m/s. We shall here interpret this as  $\lim_{t \rightarrow +\infty} v(t) = 7$ .

We shall consider two different models:

- 1) Assume that  $R$  is proportional to the velocity, i.e.  $R = C \cdot v$ . Find the particular solution of (5), for which  $v(0) = 0$ , sketch the graph of  $v(t)$  and find the constant  $C$ .
- 2) Assume that  $R$  is proportional to the square of the velocity, i.e.  $R = c_1 v^2$ .

a) First show that if  $k > 0$  and  $g - kv^2 > 0$ , then

$$\int \frac{1}{g - kv^2} dv = \frac{1}{\sqrt{gk}} \operatorname{Artanh} \left( \sqrt{\frac{k}{g}} \cdot v \right).$$

b) Then find in the present case the particular solution of (5), for which  $v(0) = 0$ . Sketch the graph of  $v(t)$  and find the constant  $c_1$ .

**A.** We are given in advance a mathematical model (a differential equation of first order where the variables can be separated). We shall use this model in two special cases. There are given some guidelines in both cases.

**D.** Follow the guidelines. Remember the two additional conditions  $v(0) = 0$  and  $\lim_{t \rightarrow +\infty} v(t) = 7$ .

**I.** 1) When  $R = C \cdot v$ , we write (5) in the form

$$m \frac{dv}{dt} = mg - C \cdot v,$$

where  $\frac{dv}{dt} > 0$ , i.e.  $mg - C \cdot v > 0$ . Then  $0 \leq v < \frac{mg}{C}$ .

By separation of the variables we get

$$\begin{aligned} t + k &= \int \frac{m}{mg - Cv} dv = -\frac{m}{C} \int \frac{d(mg - Cv)}{mg - Cv} \\ &= -\frac{m}{C} \ln(mg - Cv). \end{aligned}$$

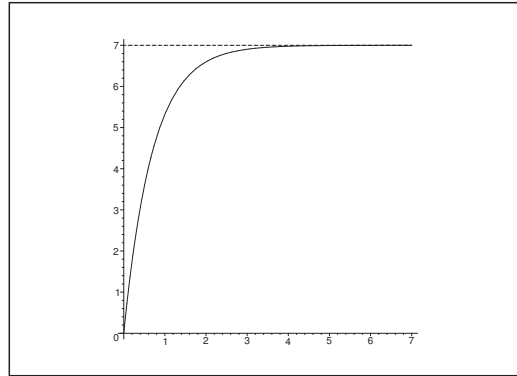

Figure 33: The graph of the solution  $v(t) = 7 \left\{ 1 - \exp\left(-\frac{g}{7}t\right) \right\}$ , for  $t \geq 0$ , and its horizontal asymptote.

From  $v(0) = 0$  we see that  $k = -\frac{m}{C} \ln(mg)$ , thus

$$\ln(mg - Cv) = \ln(mg) - \frac{C}{m}t, \quad t \geq 0,$$

and hence

$$mg - Cv = mg \exp\left(-\frac{C}{m}t\right), \quad t \geq 0,$$

i.e.

$$v(t) = \frac{mg}{C} \left\{ 1 - \exp\left(-\frac{C}{m}t\right) \right\}, \quad t \geq 0.$$

Then apply the condition  $\lim_{t \rightarrow +\infty} v(t) = 7$  to get

$$7 = \lim_{t \rightarrow +\infty} v(t) = \lim_{t \rightarrow +\infty} \frac{mg}{C} \left\{ 1 - \exp\left(-\frac{C}{m}t\right) \right\} = \frac{mg}{C},$$

thus  $C = \frac{mg}{7}$ , and the solution becomes

$$v(t) = 7 \left\{ 1 - \exp\left(-\frac{g}{7}t\right) \right\}, \quad t \geq 0.$$

With the given data,  $m = 90$  kg,  $g = 9,81 \text{ m/s}^2$ , and the limit velocity  $7$  m/s we get

$$C \approx \frac{90 \cdot 9,81}{7} \text{ kg} \cdot \text{m} \cdot \text{s}^{-2} \cdot \text{s} \cdot \text{m}^{-1} \approx 126 \text{ kg/s}.$$

Furthermore,  $\frac{g}{7} \approx 1,4 \text{ s}^{-1}$ .

Notice that  $C \cdot v$  has the physical dimension  $\text{kg} \cdot \text{m/s}^2$ , i.e. the same dimension as a force.

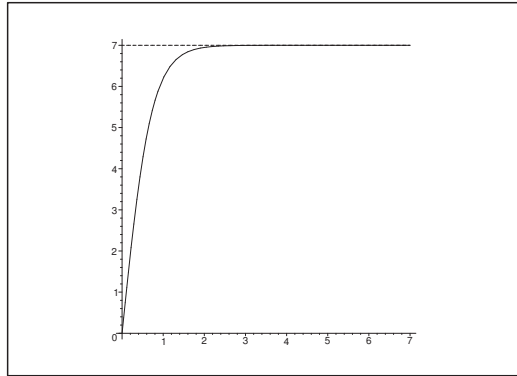

Figure 34: The graph of the solution  $v(t) = 7 \cdot \tanh\left(\frac{g}{7} \cdot t\right)$ ,  $t \geq 0$ .

2) Then let  $R = c_1 v^2$ . In this case (5) becomes

$$m \frac{dv}{dt} = mg - c_1 v^2.$$

In this case,  $\frac{dv}{dt} = mg - c_1 v^2 > 0$ , so  $0 \leq v < \sqrt{\frac{mg}{c_1}}$ . By separation of the variables followed by an integration we get

$$t + K = \int \frac{1}{g - \frac{c_1}{m} v^2} dv = \int \frac{1}{g - kv} dv, \quad k = \frac{c_1}{m} > 0.$$

a) Let

$$f(v) = \frac{1}{\sqrt{gk}} \operatorname{Artanh} \left( \sqrt{\frac{k}{g}} v \right),$$

where  $k > 0$  and  $g - kv^2 > 0$ , hence  $0 \leq \sqrt{\frac{k}{g}} v < 1$ . Then

$$f'(v) = \frac{1}{\sqrt{gk}} \cdot \frac{1}{1 - \frac{k}{g} v^2} \sqrt{\frac{k}{g}} = \frac{1}{g - kv^2},$$

and we conclude that

$$\int \frac{1}{g - kv^2} dv = \frac{1}{gk} \operatorname{Artanh} \left( \sqrt{\frac{k}{g}} v \right).$$

b) Let us return to the original task. It follows from the result in (a) that

$$t + K = \int \frac{1}{g - kv^2} dv = \frac{1}{\sqrt{gk}} \operatorname{Artanh} \left( \sqrt{\frac{k}{g}} v \right).$$

Applying the initial condition  $v(0) = 0$  we find  $K = 0$ , so

$$\operatorname{Artanh}\left(\sqrt{\frac{k}{g}}v\right) = \sqrt{gk} \cdot t,$$

and thus

$$v(t) = \sqrt{\frac{g}{k}} \cdot \tanh\left(\sqrt{gk} \cdot t\right), \quad t \geq 0.$$

From the limit condition  $\lim_{t \rightarrow +\infty} v(t) = 7$  m/s we get  $7 = \sqrt{\frac{g}{k}}$ , i.e.  $k = \frac{c_1}{m} = \frac{g}{7^2}$ , hence

$$c_1 = \frac{gm}{7^2} = \frac{9,81 \cdot 90}{49} \text{ m} \cdot \text{s}^{-2} \text{kg} \cdot (\text{sm}^{-1})^2 \approx 18 \text{ kg/m},$$

and  $\sqrt{gk} = \frac{g}{7} \approx 1,4 \text{ s}^{-1}$ .

The solution is therefore in this second model given by

$$v(t) = 7 \cdot \tanh\left(\frac{g}{7} \cdot t\right) \approx 7 \cdot \frac{e^{2,8t} - 1}{e^{2,8t} + 1}, \quad \text{for } t \geq 0.$$

## Trust and responsibility

NNE and Pharmaplan have joined forces to create NNE Pharmaplan, the world's leading engineering and consultancy company focused entirely on the pharma and biotech industries.

Inés Aréizaga Esteva (Spain), 25 years old  
Education: Chemical Engineer

– You have to be proactive and open-minded as a newcomer and make it clear to your colleagues what you are able to cope. The pharmaceutical field is new to me. But busy as they are, most of my colleagues find the time to teach me, and they also trust me. Even though it was a bit hard at first, I can feel over time that I am beginning to be taken seriously and that my contribution is appreciated.

Please click the advert



NNE Pharmaplan is the world's leading engineering and consultancy company focused entirely on the pharma and biotech industries. We employ more than 1500 people worldwide and offer global reach and local knowledge along with our all-encompassing list of services.  
[nnepharmaplan.com](http://nnepharmaplan.com)

**nne pharmaplan**<sup>®</sup>